

# VALU™ GUARD

## Safety Enclosure and Guarding Systems Stainless Steel or Aluminum

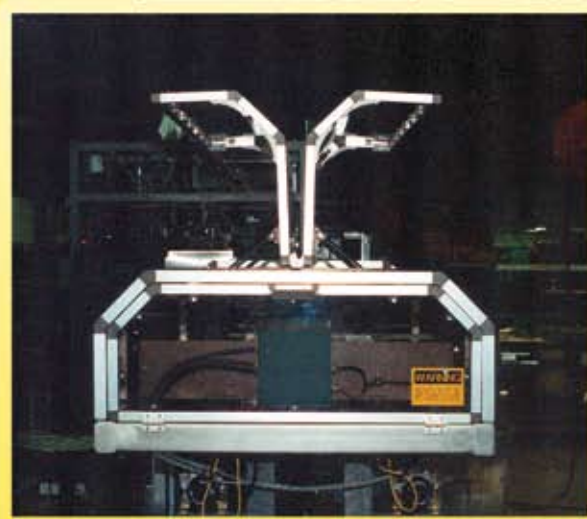

**WARNING**



**DANGER**

**OPEN GEARS**  
WATCH HANDS  
AND FINGERS

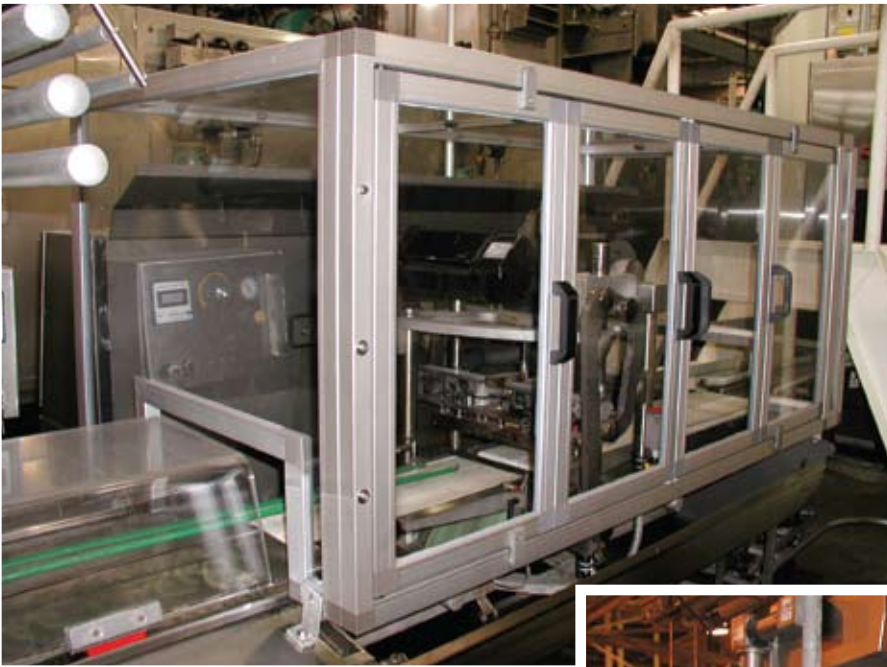

**KEEP HANDS  
CLEAR**

**CAUTION**

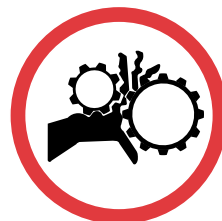

**OPEN GEARS**  
WATCH HANDS  
AND FINGERS

**DANGER**

**CAUTION**

The guarding on this machine is unsightly and a potential safety hazard. New machines or retrofit applications can benefit from Valu Guard enclosure systems.

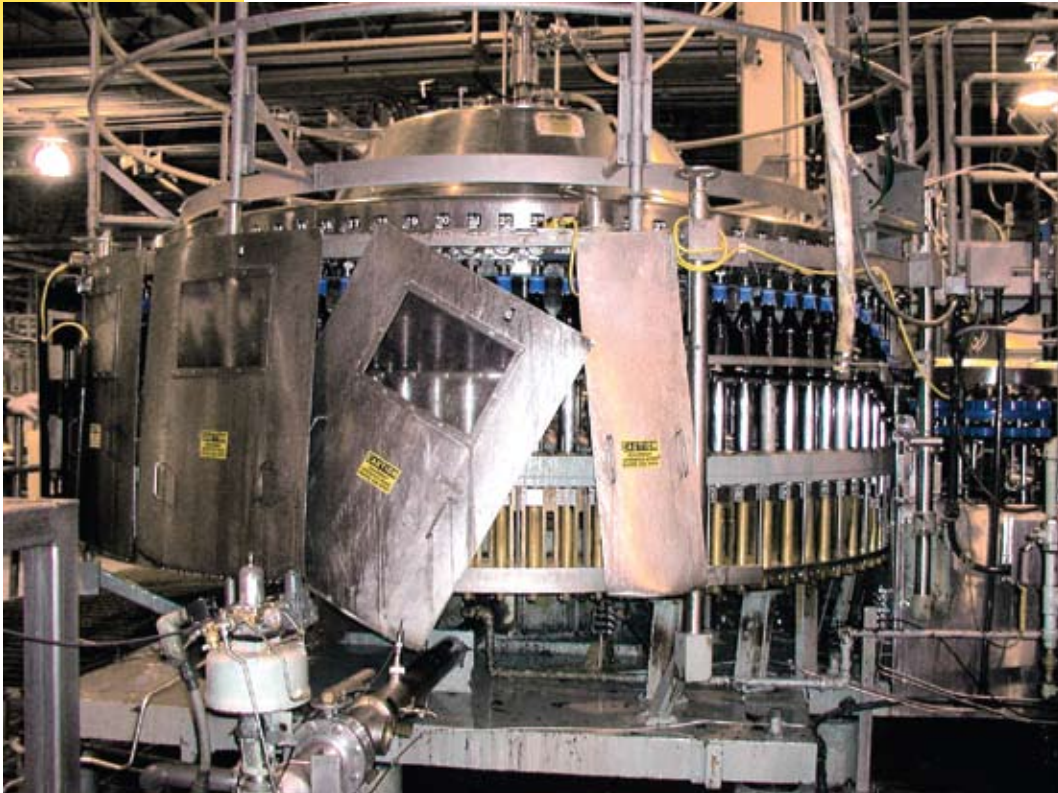

Valu Guard products give this machine a new, beautiful appearance with greater visibility and accessibility. Large or small, Valu Guard can add safety and cleanliness to your next project.

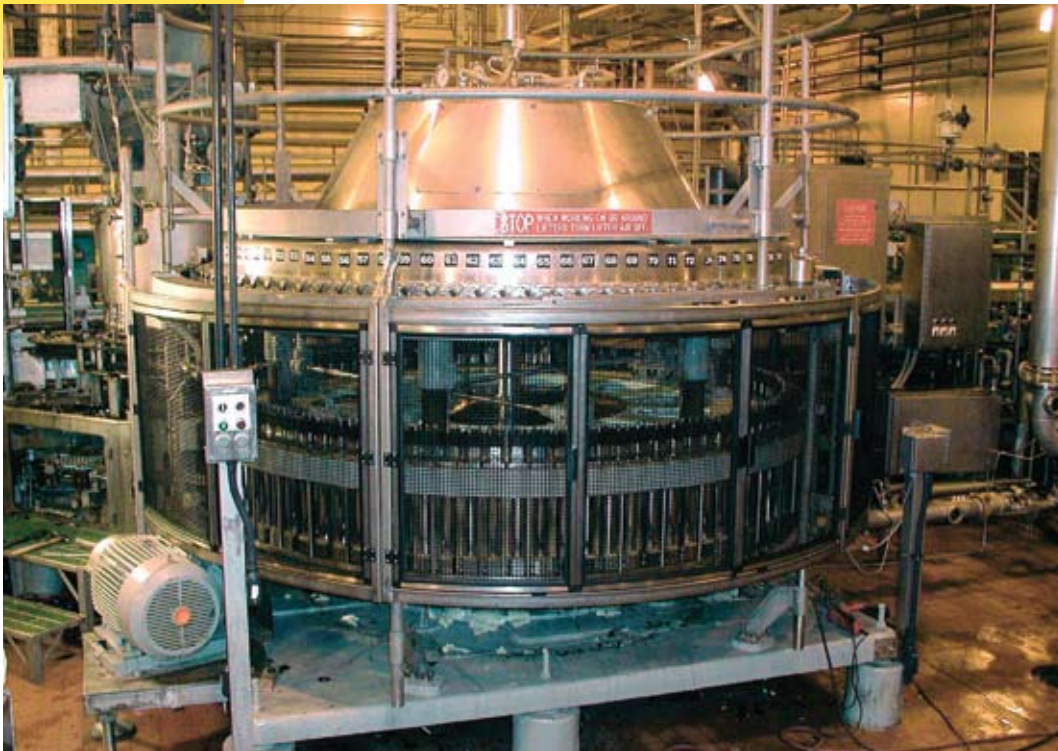

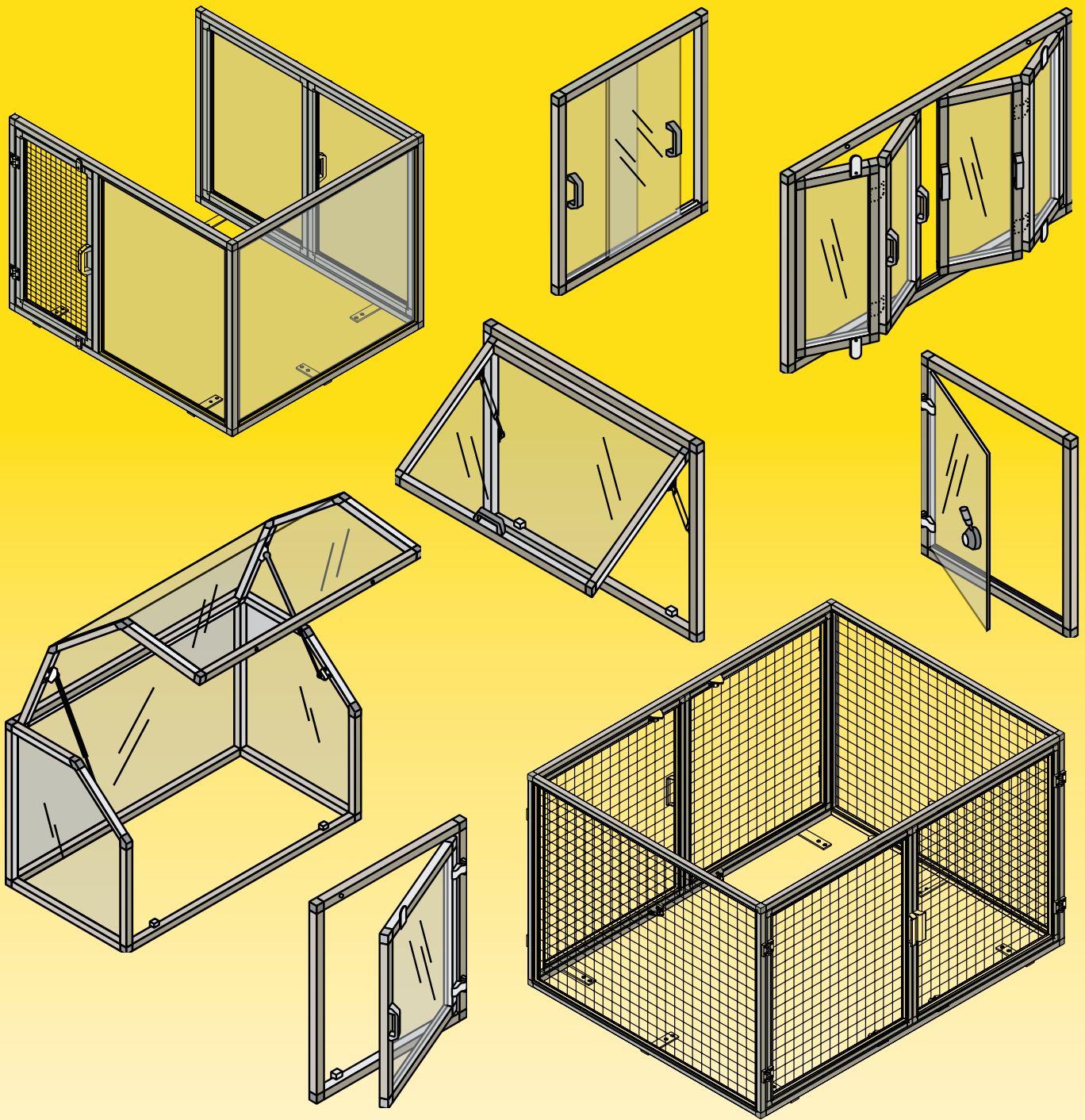

**VALU**<sup>TM</sup>  
**GUARD**

**(866) 765-8744**  
www.solusii.com  
solusteam@solusii.com

Also available from Solus Industrial Innovations:

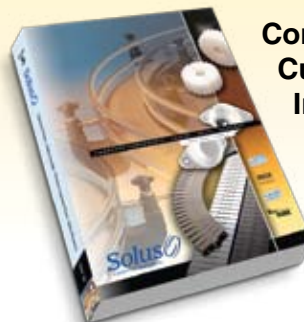

**Conveyor Components**  
**Custom Plastics**  
**Industrial Parts**



Call today for your  
copy of the latest  
catalog featuring our  
complete product line!

**Solus**<sup>®</sup>  
A System Plast Group Company

30152 Aventura  
Rancho Santa Margarita, California 92688  
phone: (949) 589-3900 fax: (949) 858-0300  
Indianapolis, IN • Sanford, NC  
Tlajomulco de Zuñiga, Jalisco, Mexico



# FLEXTECH™

- ✓ Quality Finished Appearance
- ✓ Heavy Gauge Square Aluminum Tubing
- ✓ Safety Enclosure Applications
- ✓ Reinforced Plastic Corner Joints

**Tube Shape:** square

**Tube Material:** anodized aluminum

**Tube Size:** 1" x 1" and 1.19" x 1.19"

**Applications:** Safety enclosures for machinery and other types of equipment. Also used as a framing system for environmental enclosures, clean rooms, instrument enclosures, and trade show or retail displays. The combination of versatility, ease of construction and a clean, professional appearance makes FlexTech the best choice for original equipment manufacturers and end users alike.

## Table of Contents

	Page
Introduction . . . . .	2
Typical Applications . . . . .	4
Fixed Panels . . . . .	5
Access Doors . . . . .	6
Tubing . . . . .	8
Corner Joints . . . . .	11
Seals . . . . .	15
Panel Mounting . . . . .	16
Handles . . . . .	17
Door Closures . . . . .	18
Hinges . . . . .	20
Gas Springs . . . . .	22
Braces, Brackets . . . . .	23
Accessories . . . . .	24
Quick Pick Selector . . . . .	25
Assembly and Fabrication Tips . . . . .	26
Anchoring . . . . .	27
Hardware Table . . . . .	29

FlexTech

SpeedFrame

# SpeedFrame™

- ✓ Industrial and Washdown Applications
- ✓ Square Stainless or Aluminum Tubing
- ✓ Metal or Reinforced Plastic Corner Joints

**Tube Shape:** square

**Tube Material:** brushed stainless steel  
or anodized aluminum

**Tube Size:** 1" x 1"

**Applications:** Safety enclosures, industrial framing and sanitary enclosures. Excellent for corrosive wash down environments that require a stainless steel structure.

	Page
Introduction . . . . .	30
Typical Applications . . . . .	32
Fixed Panels . . . . .	33
Access Doors . . . . .	34
Tubing . . . . .	36
Corner Joints . . . . .	38
Cladding and Glazing . . . . .	40
Panel Clamps . . . . .	42
Handles, Doorstop, Bifold Slider . . . . .	43
Latches . . . . .	44
Hinges . . . . .	46
Tube Ends . . . . .	47

## Guarding Products from *Solus*® Improve the Safety and Appearance of Your Machinery!

A System Plast Group Company

Protective enclosures keep material contained within the machine area, and prevent people or items from accidentally entering the operating machine's space. When properly constructed, the guards enhance the appearance of OEM equipment.

The two product lines, FlexTech and SpeedFrame, are based on the concept that with a pre-engineered system of components, custom structures can be made faster, more attractive and more economically than by welding or other traditional fabrication methods.

These framing systems from Solus can extend their versatility to almost any industry. Build shelves, counters, displays, cubicles, or even entire freestanding rooms. With a full line of accessories, the possibilities are only limited by your imagination.

For more information, please contact your local District Manager or one of our helpful Customer Service Representatives.

## Accelerating Production Through Innovation

Rancho Santa Margarita, California  
Indianapolis, Indiana  
Sanford, North Carolina  
Tlajomulco de Zuñiga, Jalisco, Mexico

**866-765-8744**

**www.solusii.com**



# FLEXTECH™

## Safety Enclosure System

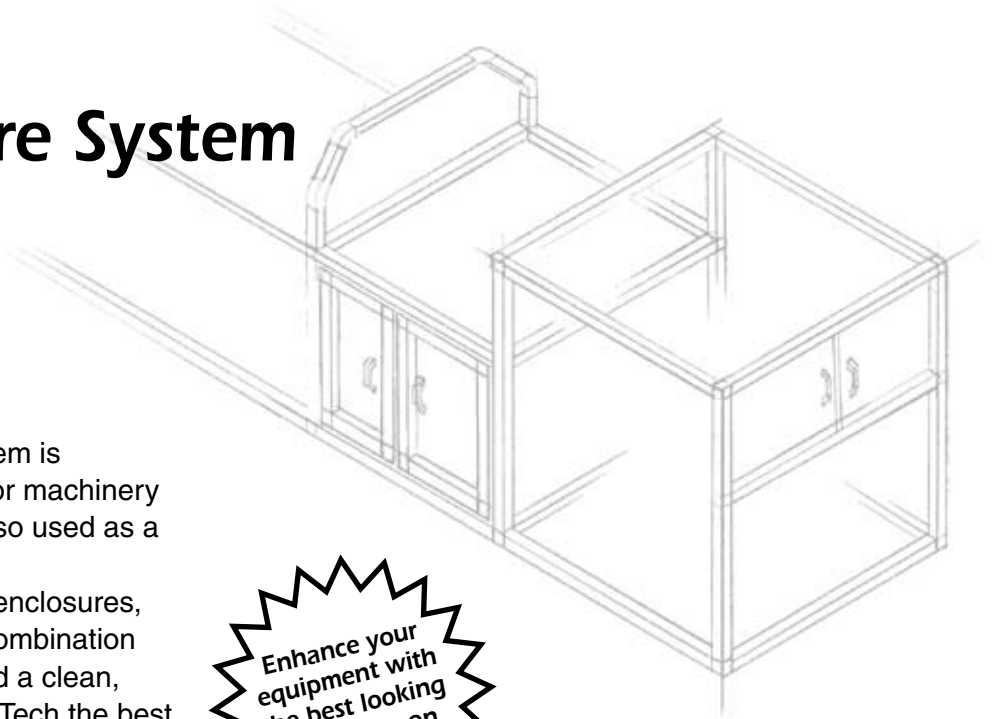

The FlexTech Safety Enclosure System is used to fabricate safety enclosures for machinery and other types of equipment. It is also used as a framing system for environmental enclosures, cleanrooms, instrument enclosures, trade show and retail displays. The combination of versatility, ease of construction and a clean, professional appearance makes FlexTech the best choice for original equipment manufacturers and end users alike.



### Features

- ◆ Heavy 14 gauge anodized aluminum extrusions - clear finish or Elox tint (matches stainless steel).
- ◆ Glass-reinforced nylon joints.
- ◆ All the hinges, handles, latches, hardware and other accessories you need.
- ◆ Create unlimited combinations of doors and panels with many different extrusion profiles.

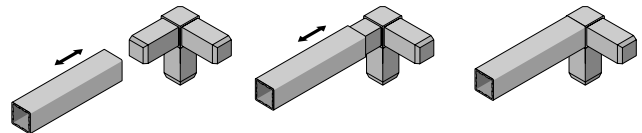

### Easy Assembly

Assemble frames using a soft-faced mallet to hammer in corner joints. Attach panels and hardware using just a drill and simple hand tools.



*FlexTech's many extrusion profiles provide the flexibility to engineer several types of doors and panels on this labeling machine.*



*FlexTech's finished appearance compliments the quality construction of this cartoner.*

### Use FlexTech if you:

- ◆ Manufacture or use equipment required to meet safety requirements.
- ◆ Have structural or complicated design requirements.
- ◆ Must have a finished appearance without T-slots or channels that catch dirt and debris.
- ◆ Require specialized doors - framed, sealed, bifold or gull wing.
- ◆ Want a stainless steel appearance but need the economy and light weight of extruded aluminum.

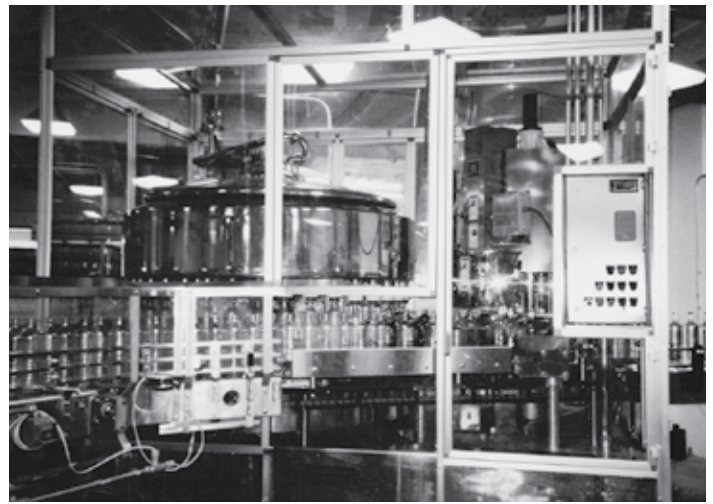

The framed door on this bottling machine has a cutout for the control panel.

### Satisfied customers include:

- ◆ Original equipment manufacturers required to have guarding on their machines.
- ◆ Process manufacturers retrofitting safety enclosures on plant equipment.
- ◆ Electronic enclosure manufacturers.
- ◆ Exhibit designers and fabricators.

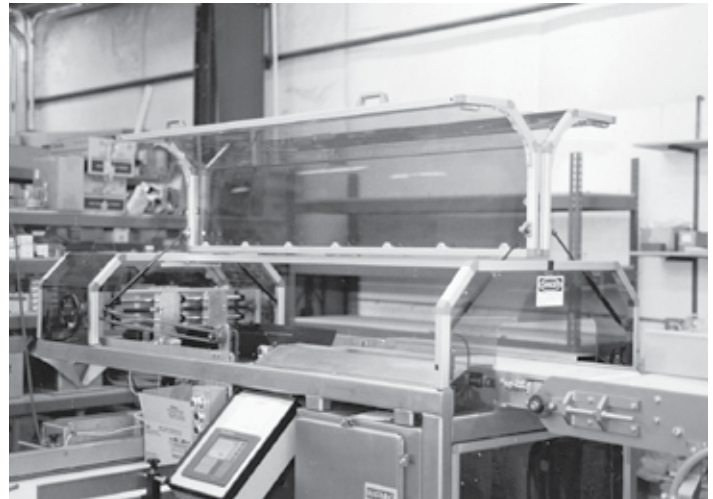
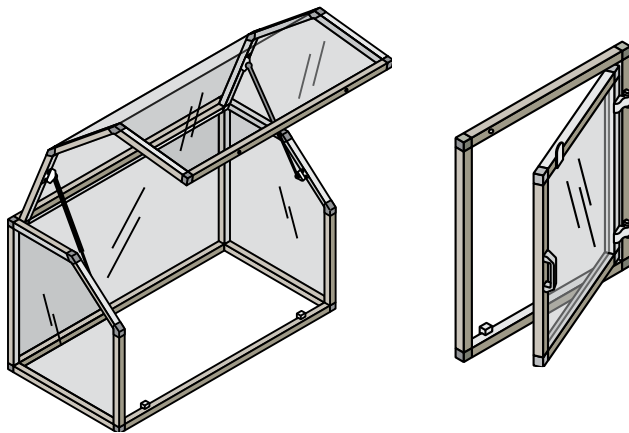

Gull wing doors with gas springs swing up and out of the way without obstructing aisle space.



This filler uses 6 ft. high bifold doors to fully enclose the star wheel while permitting unobstructed access.



Bifold doors on this free standing enclosure provide easy and unobstructed access to this bottling line.

## Typical Applications

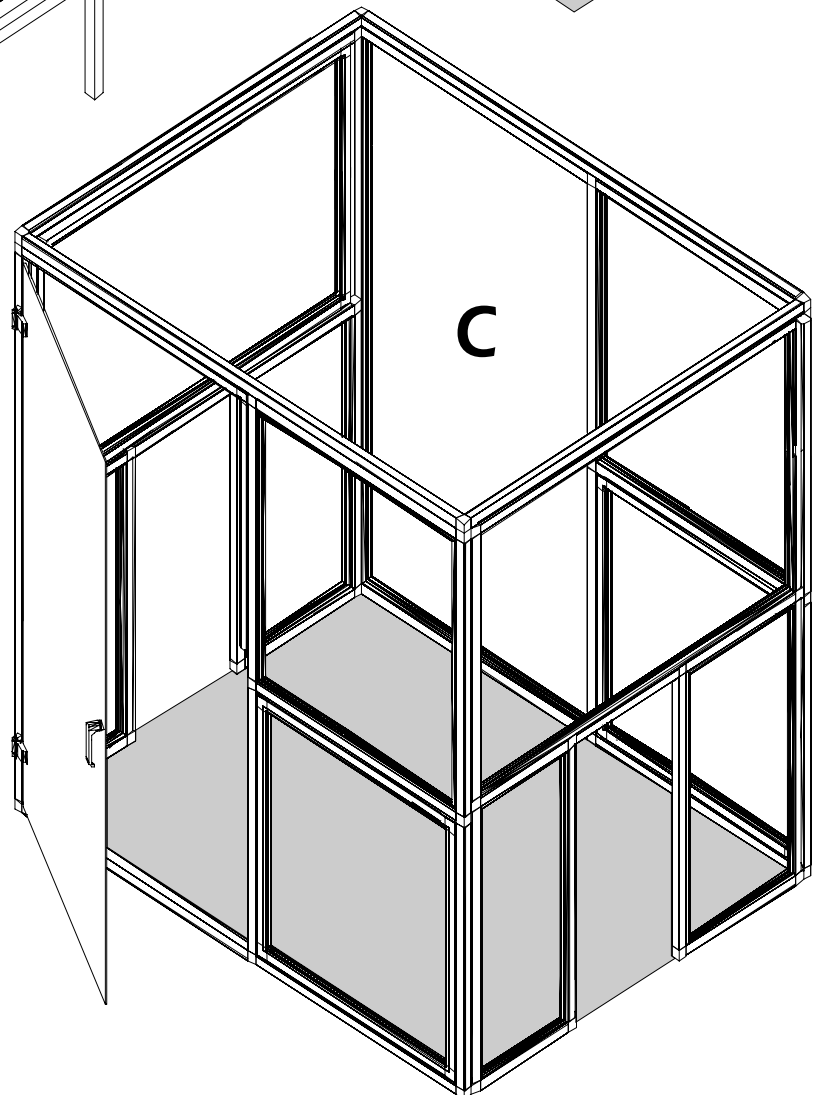
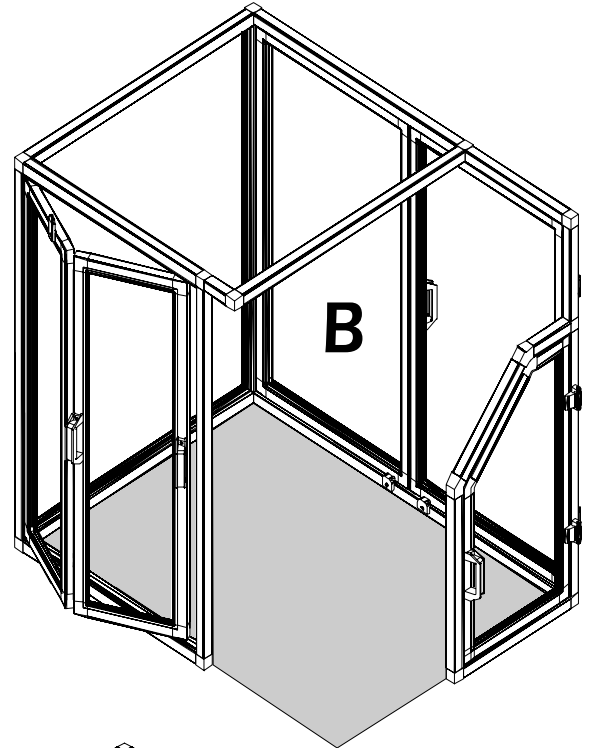
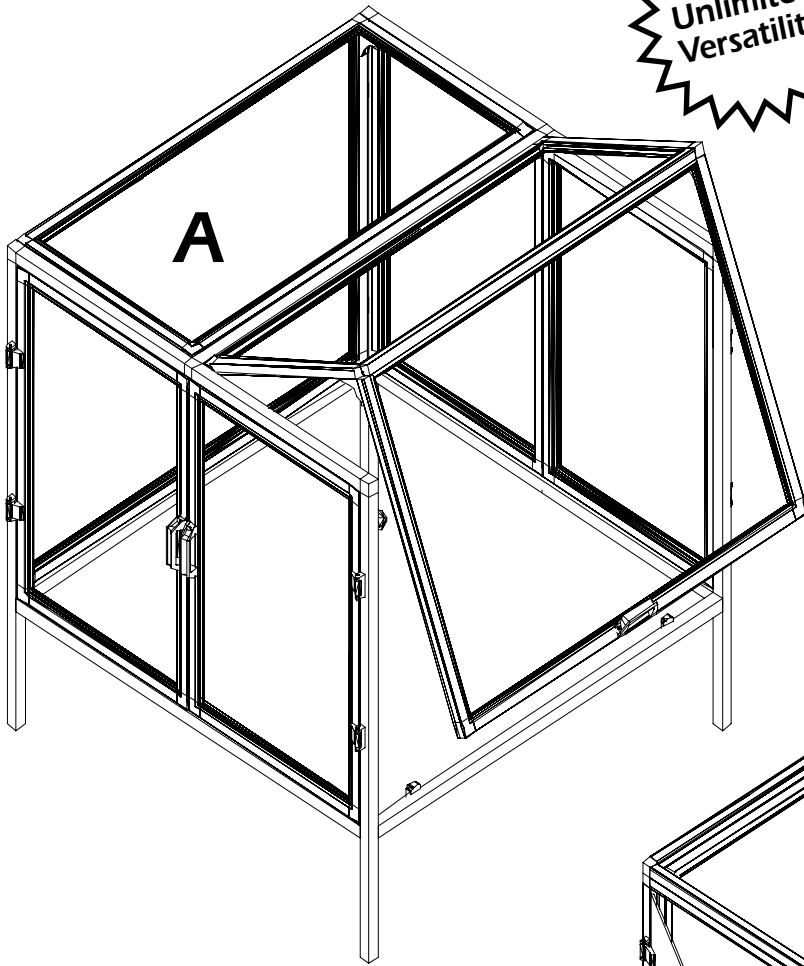

***These typical applications were built by us from customer specifications:***

**A** This fruit packager needed an enclosure with a large hatch opening for packaging machinery.

**B** This pharmaceutical manufacturer's enclosure required bifold doors and odd access angles.

**C** The sealed panel on this enclosure allows access to the machine while creating a containment area for dust generated in the production process.



# Fixed Panel Options

Tube sizes: Series **25** 1" square for doors and windows  
 Series **30** 1-3/16" square for framing structures

Tube finishes: Clear anodized aluminum (-AN)  
 Elox anodized (-LX) a unique tint to match stainless steel

Corner joint sizes: Series **25** for 1" tubes and series **30** for 1-3/16" tubes

**FlexTech Exclusive!**

FlexTech

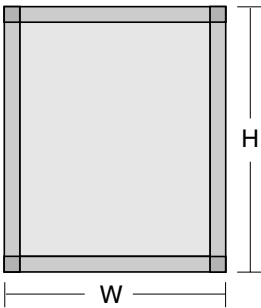

## Framed Panel with Glazing Bead

The glaze bead seals the panel into place keeping out moisture and dust while stiffening and strengthening the frame.

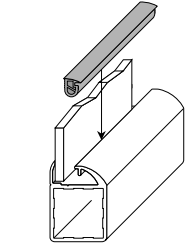

Series <b>25</b>	Series <b>30</b>
Tube .....	FT-25T-PF-10-.....FT-30T-PF-10-
Corner joint .....	FT-25-PA-J2M-GR.....FT-30-PA-J2-GR
Tube length .....	H or W minus 3".....H or W minus 2-3/8"
Wire mesh or plastic panel dim...	H or W minus 2-3/16".....H or W minus 2-9/16"
Glaze bead .....	FT-PF-GZ1- (for 3/16"-1/4" thick panel)
	..... FT-PF-GZ2- (for 1/16"-1/8" thick panel or wire mesh)

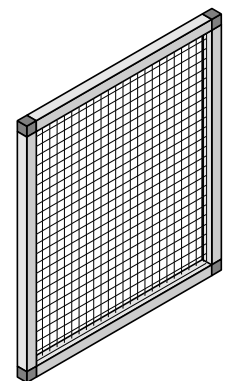

## Framed Panel with Panel Mounting Blocks

The panel mounting blocks and clamps allow the panel to be removed or replaced. Used where a sealed panel is not required.

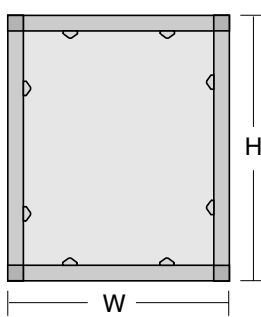

Series <b>25</b>	Series <b>30</b>
Tube .....	FT-25T-10-.....FT-30T-10-
Corner joint .....	FT-25-PA-J2-GR.....FT-30-PA-J2-GR
Tube length .....	H or W minus 2".....H or W minus 2-3/8"
Plastic panel dimensions .....	H or W minus 2-1/16".....H or W minus 2-7/16"
Panel mounting block .....	FT-PMB-01-CLR (approx 6" apart)
One sided pop-in panel clamp....	FT-PMC1-GR (approx 6" apart)
Two sided pop-in panel clamp ....	FT-PMC2-GR
Wire mesh or plastic panel dim ..	H or W minus 2-3/4".....H or W minus 3-1/8"

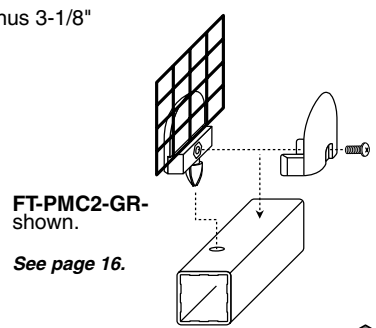
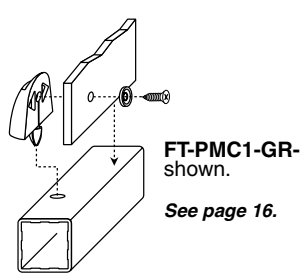
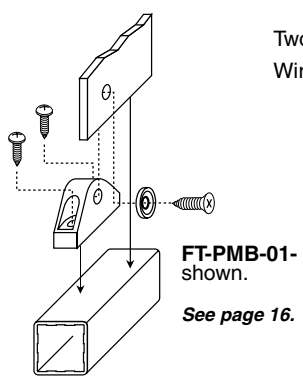
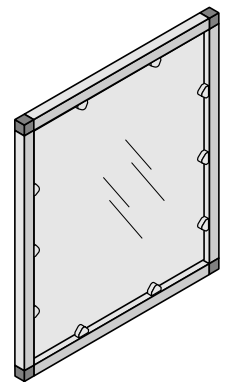

## Framed Panel with Panel Mounting Tube

The profile allows the panel to be removed or replaced. Screws are not visible from the outside of the enclosure.

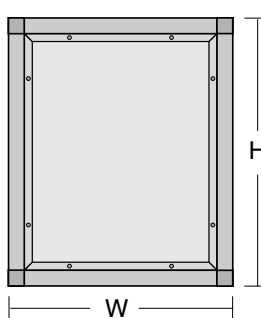

Series <b>30</b>	
Tube .....	FT-30T-PM-10-
Corner joint .....	FT-30-PA-J2-GR
Tube length .....	H or W minus 2-3/8"
Plastic panel dimensions .....	H or W minus 2-7/16"
Panel mounting kit .....	FT-PMK

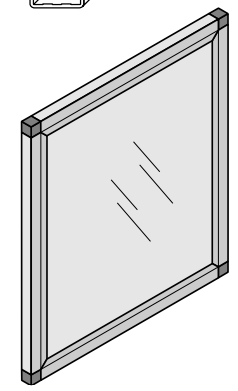
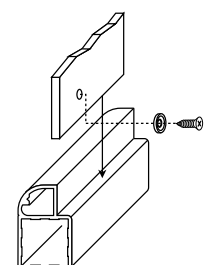

# FLEXTECH™

## Access Door Options

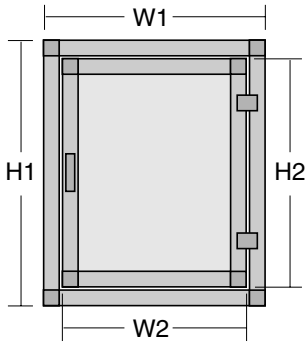

### Framed Door

The free swinging style is the most common door, appropriate for most applications. The hatch style is most often used for wide doors or when full access to the door opening is needed.

If the FT-30T-FDS-10- extrusion is used, the door will seal against it.

Frame around door  $H_1 \times W_1$

Series **30**

Tube ..... FT-30T-10- or FT-30T-FDS-10-  
 Corner joint ..... FT-30-PA-J2-GR  
 Tube length .....  $H_1$  or  $W_1$  minus 2-3/8"

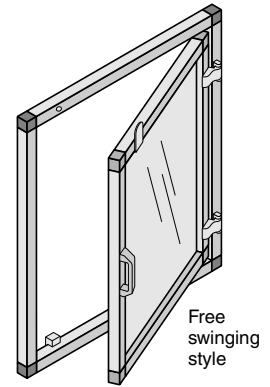

Door Panel  $H_2 = H_1$  minus 2-5/8"  
 $W_2 = W_1$  minus 2-5/8"

(allows for 1/8" gap between frame and door)

Series **25**

Tube ..... FT-25T-PF-10-  
 Corner joint (miterless) ..... FT-25-PA-J2M-GR  
 Tube length .....  $H_2$  or  $W_2$  minus 3"  
 Wire mesh or plastic panel dim. ....  $H_2$  or  $W_2$  minus 2-3/16"  
 Glazing bead ..... FT-PF-GZ1- (for 3/16"-1/4" thick panel)  
 ..... FT-PF-GZ2- (for 1/16"-1/8" thick panel  
 or wire mesh)

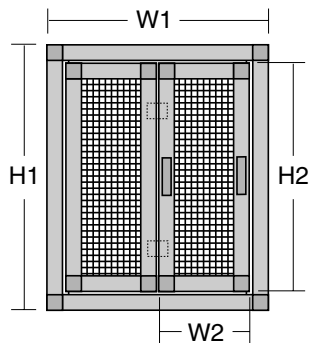
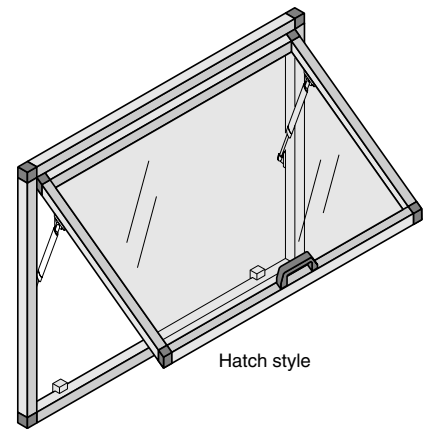

### Single Bifold Door

Most commonly used when limited door swing space is available and maximum access is needed.

Frame around door  $H_1 \times W_1$

Series **30**

Vertical tube ..... FT-30T-10-  
 Horizontal tube ..... FT-30T-PT-10-  
 Corner joint ..... FT-30-PA-J2-GR  
 Tube length .....  $H_1$  or  $W_1$  minus 2-3/8"

Bifold Door Panels  $H_2 = H_1$  minus 3-3/8"  
 $W_2 = (W_1 \text{ minus } 2-5/8") \div 2$

Series **25**

Tube ..... FT-25T-PF-10-  
 Corner joints (miterless) ..... FT-25-PA-J2M-GR (2)  
 ..... FT-25-PA-JMLH-GR (1)  
 ..... FT-25-PA-JMRH-GR (1)  
 Tube length .....  $H_2$  or  $W_2$  minus 3"  
 Wire mesh or plastic panel dim. ....  $H_2$  or  $W_2$  minus 2-3/16"  
 Glazing bead ..... FT-PF-GZ1- (for 3/16"-1/4" thick panel)  
 ..... FT-PF-GZ2- (for 1/16"-1/8" thick panel or wire mesh)

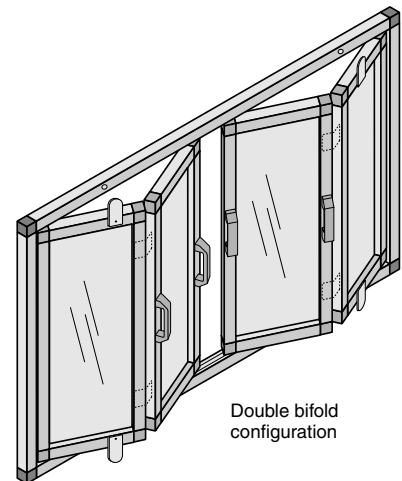

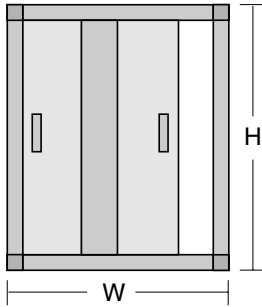

## Sliding Panel Doors

Economical alternative when little or no door swing space is available.

### Series 25

### Series 30

Vertical tube .....	FT-25T-10-	FT-30T-10-
Top horizontal tube .....	FT-25T-SPT-10-	FT-30T-SPT-10-
Bottom horizontal tube .....	FT-25T-SPB-10-	FT-30T-SP-10-
Corner joint .....	FT-25-PA-J2-GR	FT-30-PA-J2-GR
Tube length .....	H or W minus 2"	H or W minus 2-3/8"
Plastic panel dim .....	H minus 2-3/8"	H minus 3-1/8"
.....	((W minus 2") ÷ 2) + 1/2"	((W minus 2-3/8") ÷ 2) + 1/2"

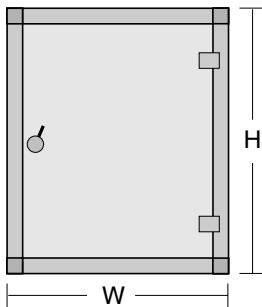
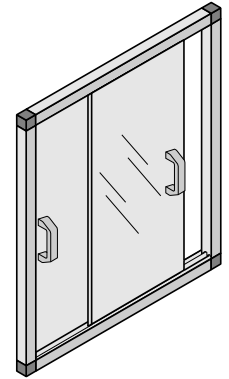

## Unframed Panel Door with Door Seal Bead

Door is a piece of sheet plastic that is hinged to the frame. Latch secures door against flexible seal. Commonly used when enclosing dusty or wet environments.

### Series 25

### Series 30

Tube .....	FT-25T-PS-10-	FT-30T-PS-10-
Corner joint .....	FT-25-PA-J2-GR	FT-30-PA-J2-GR
Tube length .....	H or W minus 2"	H or W minus 2-3/8"
Plastic panel dim. ....	H or W minus 2-1/2"	H or W minus 2-7/8"
Door seal bead .....	FT-PS-DS1-GR (for 1/4"-3/8" panels and Series 25 or 30 tubes)	

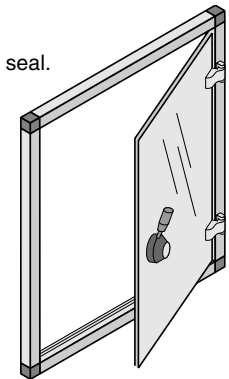

## Gull Wing Door

Gull wing doors swing up and out of the way and are ideal for areas where aisle space is limited.

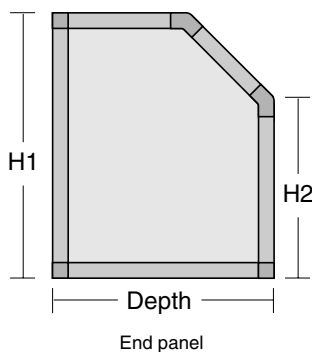

### Frame around door

### Series 30

Vertical tube .....	FT-30T-PF-10-
Horizontal tubes .....	FT-30T-PF-10-, FT-30T- (bottom front)
Corner joints .....	FT-30-PA-J3S-GR (6)
.....	FT-30-PA-J2RS-45-GR (4)

### Gull Wing Door Panel

### Series 25

Tube .....	FT-25T-PF-10-
Corner joints .....	FT-25-PA-J2RS-45-GR (4)
Corner joints (miterless) .....	FT-25-PA-J2M-GR (2)
.....	FT-25-PA-JMLH-GR (1)
.....	FT-25-PA-JMRH-GR (1)
45° side adapter .....	FT-25-ADP-R2-GR (4)

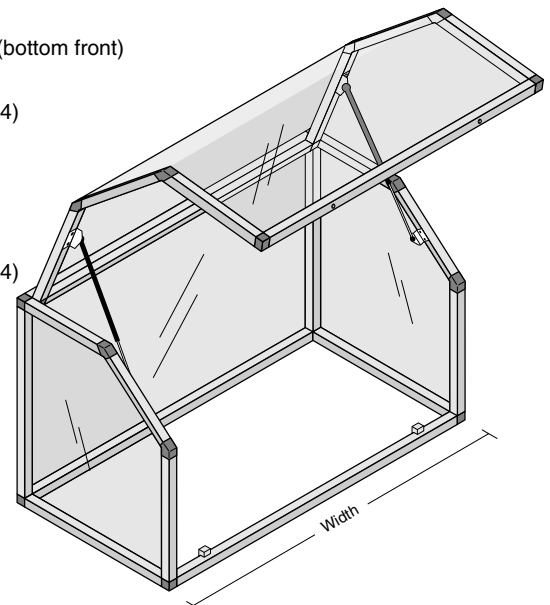

For panel and tube dimensions, please contact the Engineering Services Group with H1, H2, depth, and width.

## Tubing Profiles

- 80 mil wall thickness, internally ribbed for greater strength and stiffness
- Two sizes available for most tubes: Series **25** 1" square for panels and doors
- Available in 10 ft. lengths
- Series **30** 1-3/16" square for framing structures
- 6063 T6 anodized aluminum in two finishes: Clear (-AN) and Elox tint (-LX) to match stainless steel

**FlexTech Exclusive!**

### Square Aluminum Tube

FT-25T-10-AN  
FT-25T-10-LX  
FT-30T-10-AN  
FT-30T-10-LX

Used for basic frame structure.

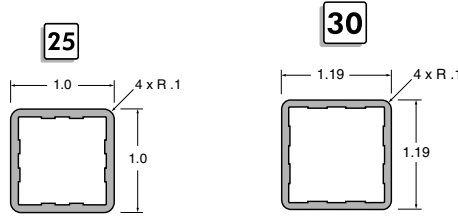
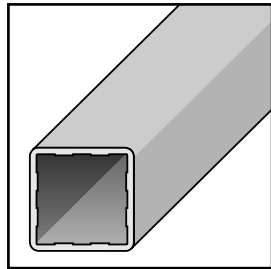

### Panel Glazing Tube

FT-25T-PF-10-AN  
FT-25T-PF-10-LX  
FT-30T-PF-10-AN  
FT-30T-PF-10-LX

Retains and seals panels from 1/16" to 3/8" thick. Requires FT-PF-GZ1- or FT-PF-GZ2 glazing bead.

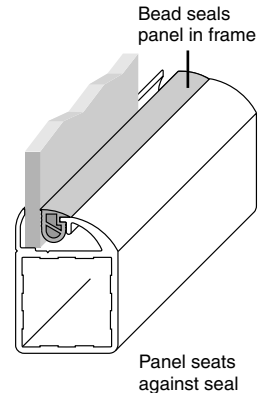
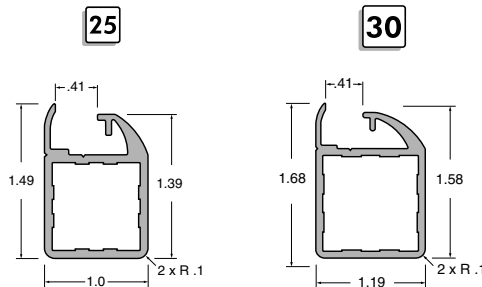
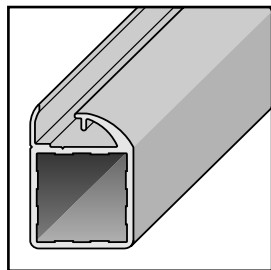

### Panel Seal Tube

FT-25T-PS-10-AN  
FT-25T-PS-10-LX  
FT-30T-PS-10-AN  
FT-30T-PS-10-LX

Used to make frameless sealed doors using panels from 1/4" to 3/8" thick. Requires FT-PS-DS1-door seal.

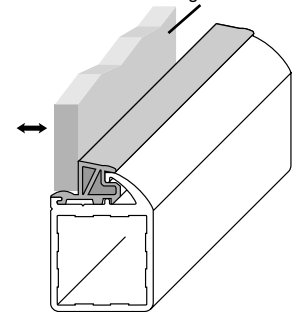
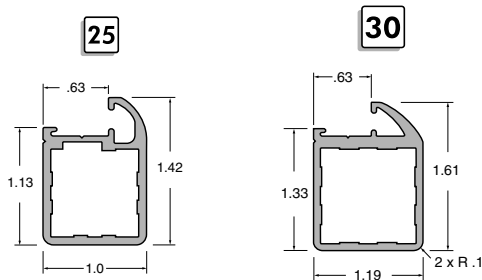
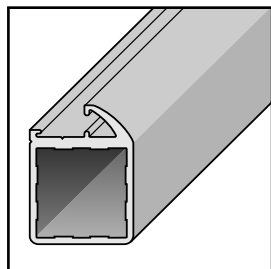

### 180° Panel Glazing Tube

FT-25T-PF-180-10-AN  
FT-25T-PF-180-10-LX  
FT-30T-PF-180-10-AN  
FT-30T-PF-180-10-LX

Retains and seals two adjacent panels from 1/16" to 3/8" thick. Requires FT-PF-GZ1- or FT-PF-GZ2- glazing bead.

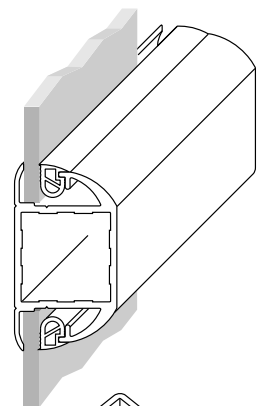
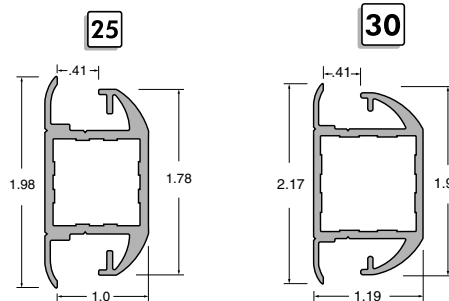
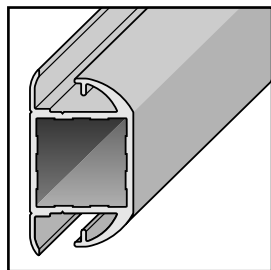

### 90° Panel Glazing Tube

FT-30T-PF-90-10-AN

Retains and seals two panels from 1/16" to 3/8" thick in a corner. Requires FT-PF-GZ1- or FT-PF-GZ2- glazing bead.

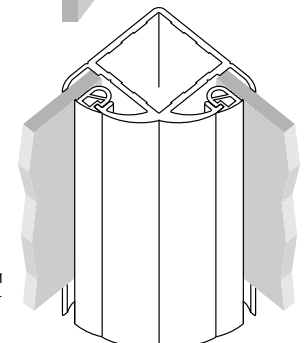
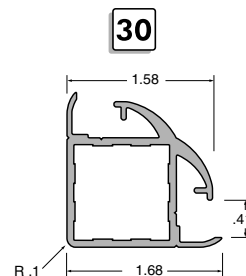
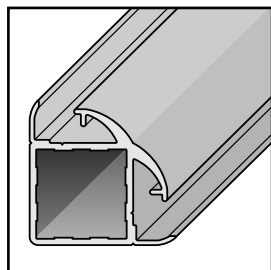

**Bifold Track Tube**  
**FT-30T-PT-10-AN**  
**FT-30T-PT-10-LX**

Used as upper and lower outside frame for bifold doors. Groove in tube retains the sliding pin (FT-PIN1-DL) attached to the bifold doors.

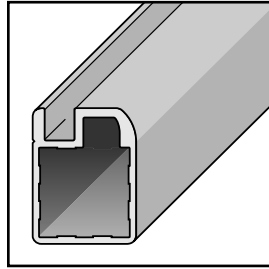

30

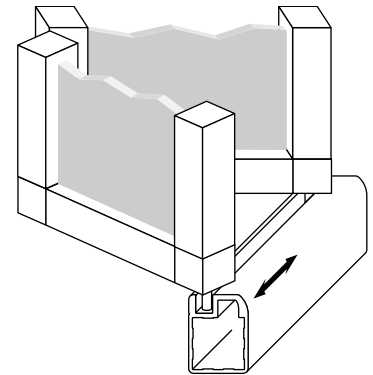
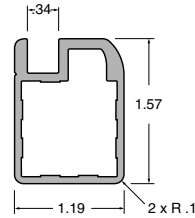

**Bifold Track Adapter**  
**FT-30C-PT-10-AN**  
**FT-30C-PT-10-LX**

Fastens to tubing. Used when the sliding track tube can't be used. See page 26 for mounting details.

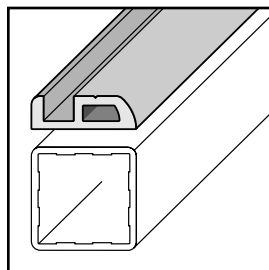

30

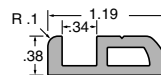

**Panel Glazing Adapter**  
**FT-25C-PF-10-AN**  
**FT-25C-PF-10-LX**  
**FT-30C-PF-10-AN**  
**FT-30C-PF-10-LX**

Fastens to tubing. Used to retain and seal panels when the panel glazing tube can't be used. See page 26 for mounting details.

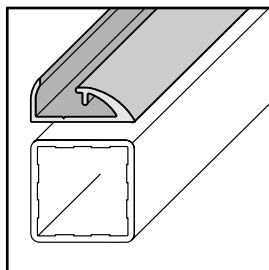

25

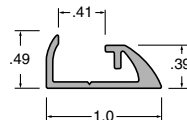

30

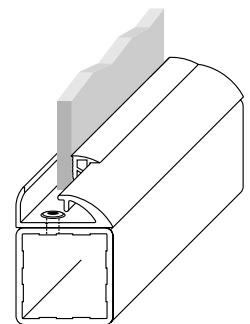
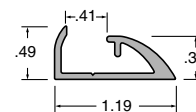

**Panel Seal Adapter**  
**FT-25C-PS-10-AN**  
**FT-25C-PS-10-LX**  
**FT-30C-PS-10-AN**  
**FT-30C-PS-10-LX**

Fastens to tubing. Used to make a frameless sealed door when the panel seal tube can't be used. See page 26 for mounting details.

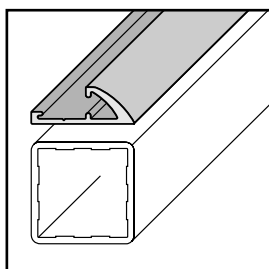

25

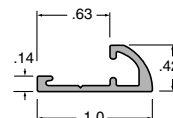

30

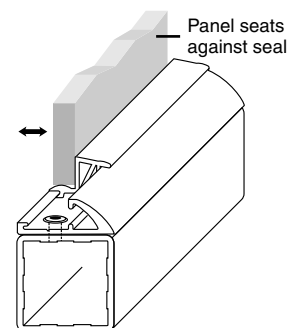
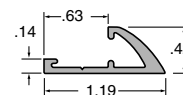

## Framed Door Seal Tube FT-30T-FDS-10-AN FT-30T-FDS-10-LX

Used as a frame around a Series 25 door. Door seats against seal bead to keep dust, spray and noise inside of enclosure. See page 15 for seal bead.

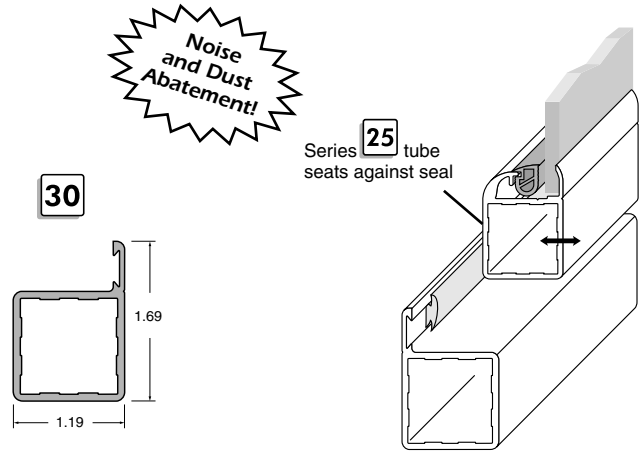
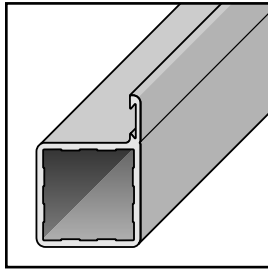

## Panel Mounting Tube FT-30T-PM-10-AN FT-30T-PM-10-LX

Used to mount removable panels up to 1/4" thick.

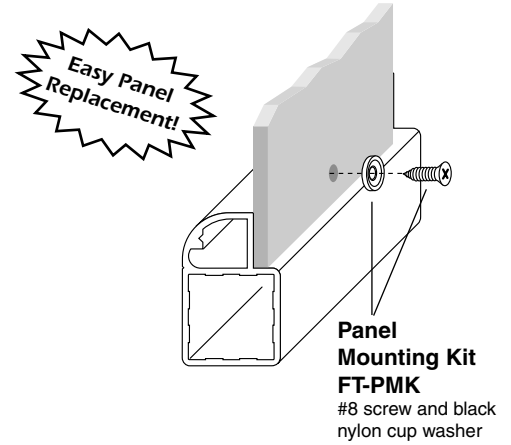
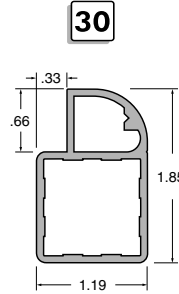
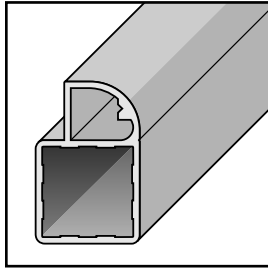

## Sliding Panel Tube FT-25T-SPT-10-AN (top) FT-25T-SPT-10-LX (top) FT-25T-SPB-10-AN (bottom) FT-25T-SPB-10-LX (bottom)

Used to make sliding doors with panels up to 1/4" thick. Deeper top channels permit lift-out panel removal.

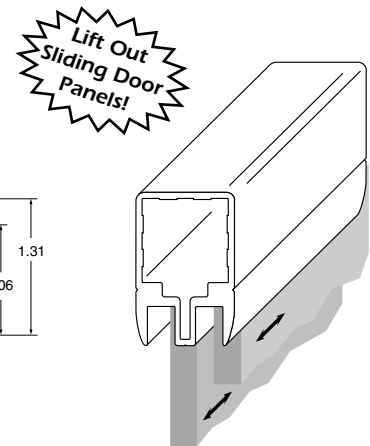
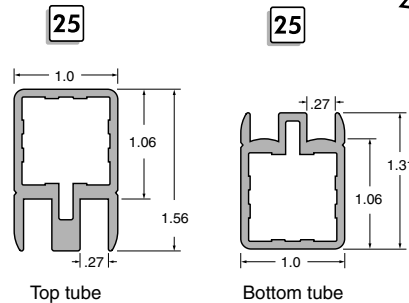
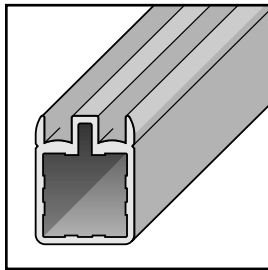

# Corner Joints

- Glass reinforced polyamide construction tightly connects tube sections
- Gray color
- Two sizes available: For Series **25** tubing  
For Series **30** tubing

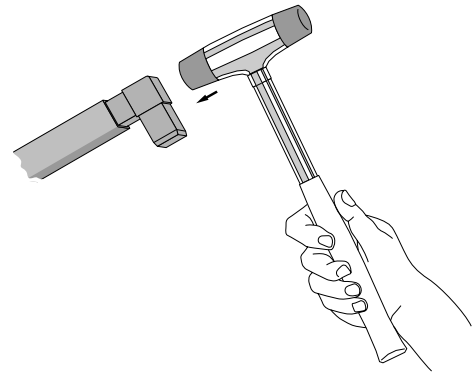

**90° Corner Joint**  
**FT-25-PA-J2-GR**  
Connects two Series 25 tubes at a corner.

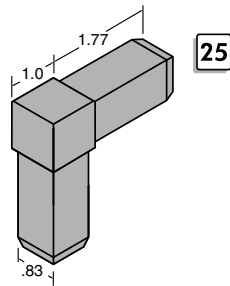

**90° Corner Joint**  
**FT-30-PA-J2-GR**  
Connects two Series 30 tubes at a corner.

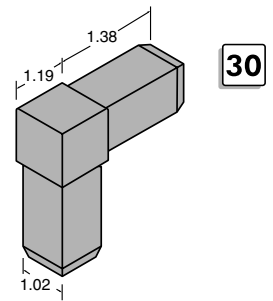

**Tee Joint**  
**FT-25-PA-JT3-GR**  
Connects three Series 25 tubes at a tee.

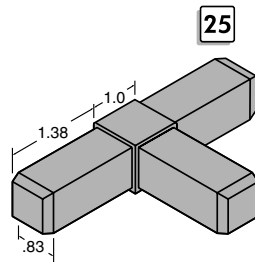

**Tee Joint**  
**FT-30-PA-JT3-GR**  
Connects three Series 30 tubes at a tee.

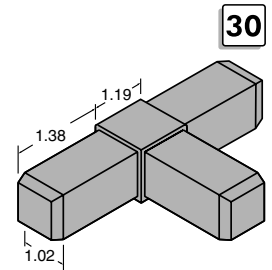

**3 Way Corner Joint**  
**FT-25-PA-J3-GR**  
Connects three Series 25 tubes at a corner.

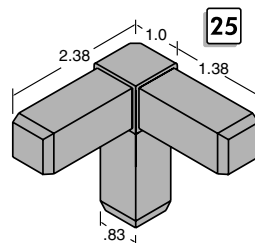

# Steel Reinforced Corner Joints

- Glass reinforced nylon with steel inserts are up to 50% stronger than unreinforced joints
- Gray color
- Two sizes available: For Series **25** tubing  
For Series **30** tubing

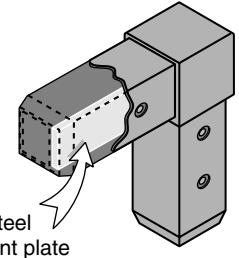

Molded-in steel reinforcement plate

## 90° Corner Joint FT-25-PA-J2S-GR

Connects two Series 25 tubes at a corner.

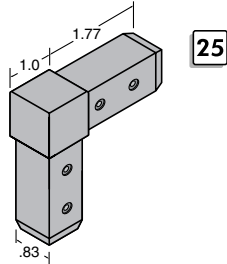

## 90° Corner Joint FT-30-PA-J2S-GR

Connects two Series 30 tubes at a corner.

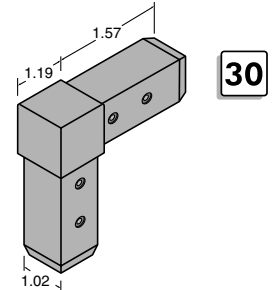

## 45° Corner Joint FT-25-PA-J2RS-45-GR

Most commonly used with Series 25 tubes on gull wing doors. On smaller doors, eliminates the need to use a 45° brace.

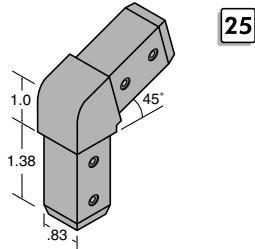

## 45° Corner Joint FT-30-PA-J2RS-45-GR

Most commonly used with Series 30 tubes for frames around gull wing doors.

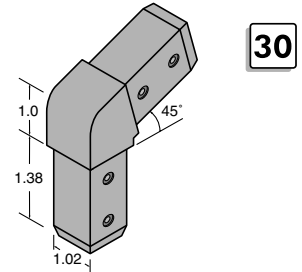

## 90° Rounded Corner Joint FT-25-PA-J2RS-GR

Connects two Series 25 tubes at a corner.

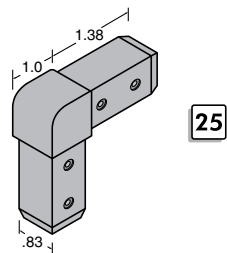

## 90° Rounded Corner Joint FT-30-PA-J2RS-GR

Connects two Series 30 tubes at a corner.

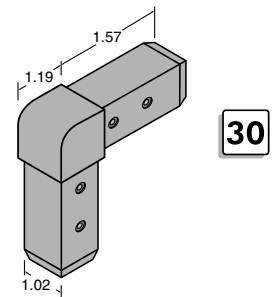

## 3 Way Corner Joint FT-30-PA-J3S-GR

Connects three Series 30 tubes at a corner.

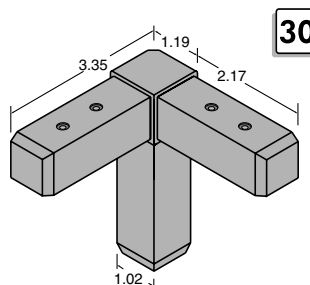



# Special Corner Joints



## Miterless Corner Joint

### FT-25-PA-J2M-GR

The built-in miter is a time saving feature which eliminates the need to make miter cuts on the tube. Used with Series 25 Panel Glazing Tube only.

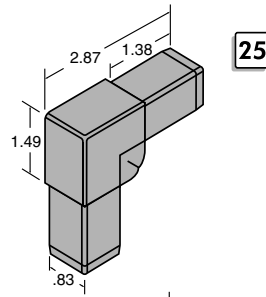

## Rounded Miterless Corner Joint

### FT-25-PA-J2MR-GR

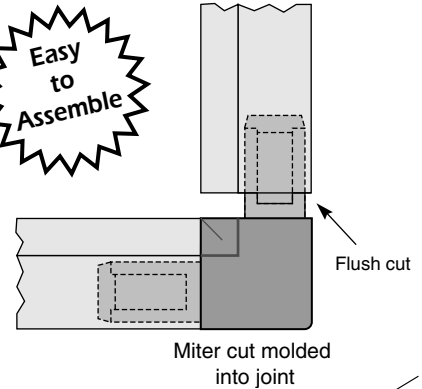
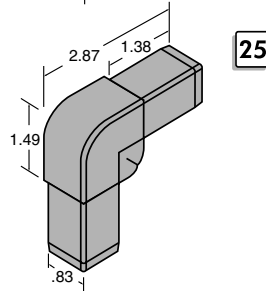

## Internal Hinge Corner Joints

Sockets built into the corner joint accept steel hinge pins. Right or left hand versions are defined by the offset location of the socket on the corner joint. The socket location is offset 3/16" so that the Series 25 framed door will be flush with the outside of the Series 30 frame. See page 21 for hinge details.

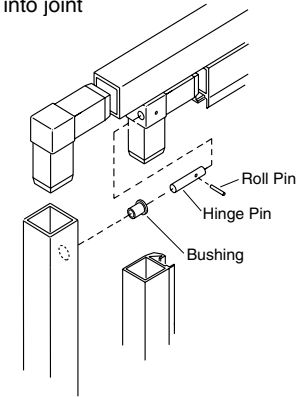
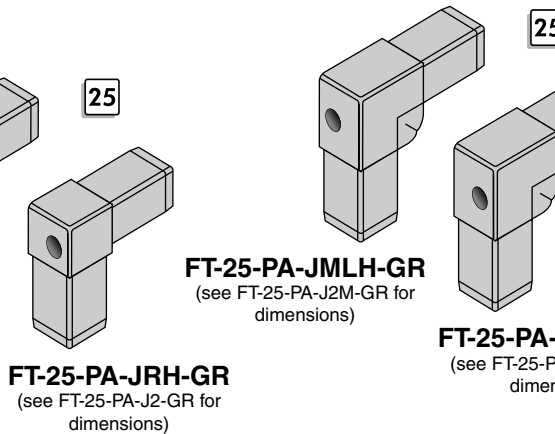

## Internal Connectors

### FT-25-PA-PLG

### FT-30-PA-PLG

Connects two tubes at 90° without using a 90° Corner Joint. Used to make 4, 5, and 6 way connections. Available in gray polyamide.

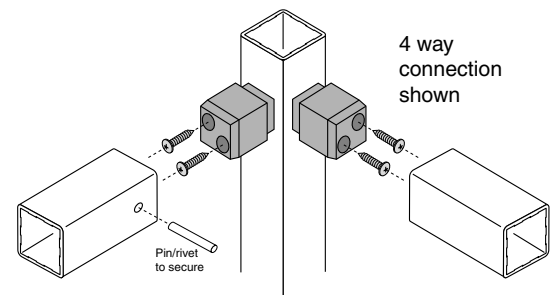
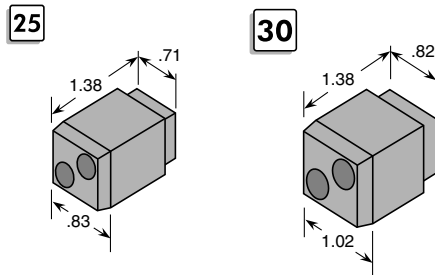

## Miterless Tee Connectors

### FT-25-PA-MT

### FT-30-PA-MT

Connects two panel glazing tubes at 90° without requiring a miter cut. See page 26 for hardware mounting details. Available in gray polyamide.

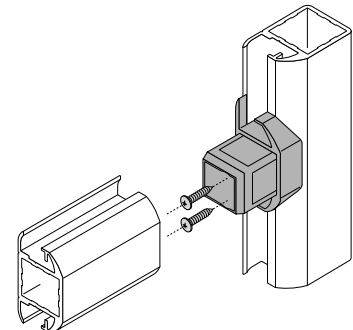
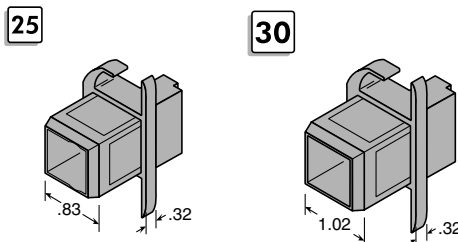

## Adapters

■ Gray color

### Internal Corner Adapter

**FT-25-ADP-01-GR**

**FT-30-ADP-01-GR**

Reinforced polyamide adapters are used to capture 1/4" or thinner panels when Panel Glazing Tubing is used to create an internal corner. Fasteners included.

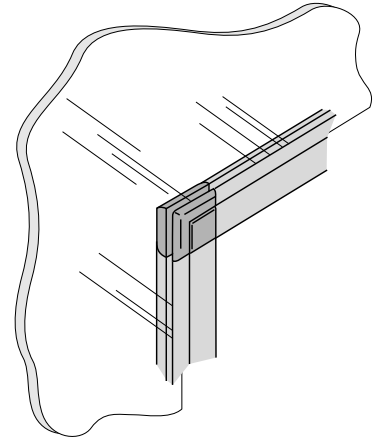
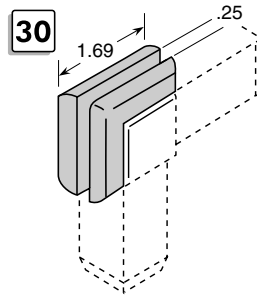
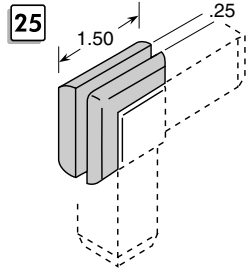

### 90° Side Adapter

**FT-25-ADP-R1-GR**

Reinforced polyamide adapters are used to capture 90° curved panels. Used with Series 25 Panel Glazing Tube, 90° Rounded Corner Joint, and 1/4" or thinner panel. Fasteners included.

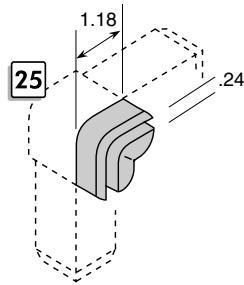

### 45° Side Adapter

**FT-25-ADP-R2-GR**

Reinforced polyamide adapters are used to capture 1/4" or thinner plastic panels on framed gull wing doors. Used with Series 25 Panel Glazing Tube and 45° Rounded Corner Joint. Fasteners included.

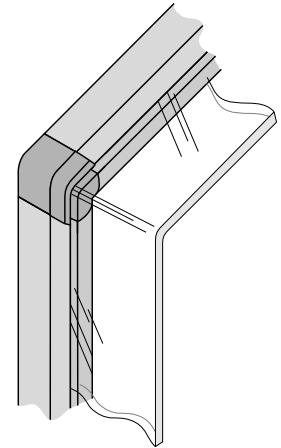
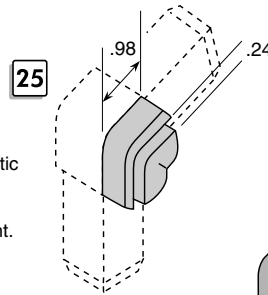

## Panel Materials

FlexTech structures can be made with a wide variety of panel materials. The material typically used is clear or tinted plastic panels. Panel thickness, depending on the tubes and accessories used, can vary from 1/16" to 3/8". Clear plastic panels are available with kits or complete enclosures ordered from our Engineering Services Group.

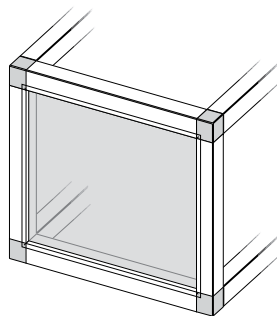

FlexTech with plastic panel.

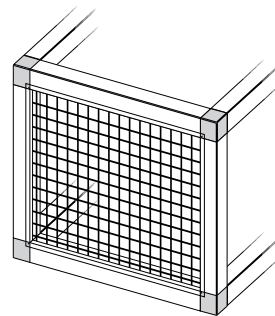

FlexTech with wire mesh panel.

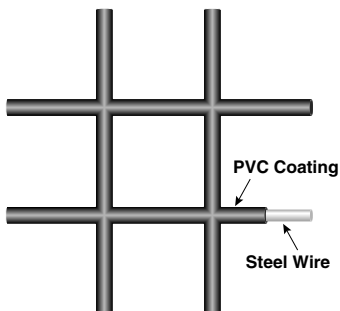
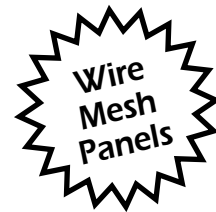

### Wire Mesh Panels

**FT-MESH-**

PVC coated wire mesh is the preferred panel material for certain structures, and can be specified through our Engineering Services Group, or ordered separately. Wire mesh sizes are 1/2" x 1/2" or 1" x 1", and are available in black or safety yellow. Panel sizes are 4' x 8'.

### 48" x 96" Panels

Part Number	Mesh Size	Color
<b>FT-MESH-4x8-05-YL</b>	1/2" x 1/2"	<b>Safety Yellow</b>
<b>FT-MESH-4x8-05-BK</b>	1/2" x 1/2"	<b>Black</b>
<b>FT-MESH-4x8-10-YL</b>	1" x 1"	<b>Safety Yellow</b>
<b>FT-MESH-4x8-10-BK</b>	1" x 1"	<b>Black</b>

# Panel Seals

## Panel Glazing Bead

**FT-PF-GZ1-10-GR**

**FT-PF-GZ1-30-GR**

For 3/16" to 1/4" thick panels.

**FT-PF-GZ2-10-GR**

**FT-PF-GZ2-30-GR**

For 1/16" to 1/8" thick panels.

Retains and seals panels in Series 25 and 30 Panel Glazing Tubes or Panel Glazing Adapters.

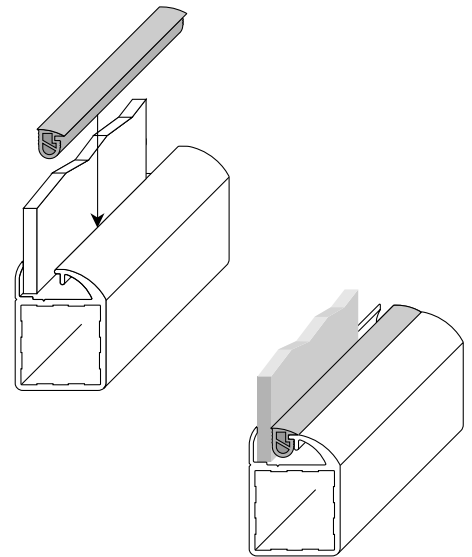
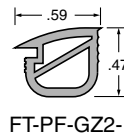
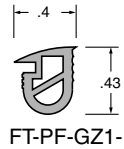
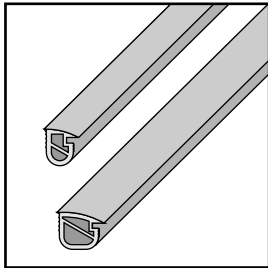

FlexTech

## Panel Seal

**FT-PS-DS1-10-GR**

**FT-PS-DS1-30-GR**

Used on FT-25T-PS- or FT-30T-PS- Panel Seal Tube to make frameless sealed doors.

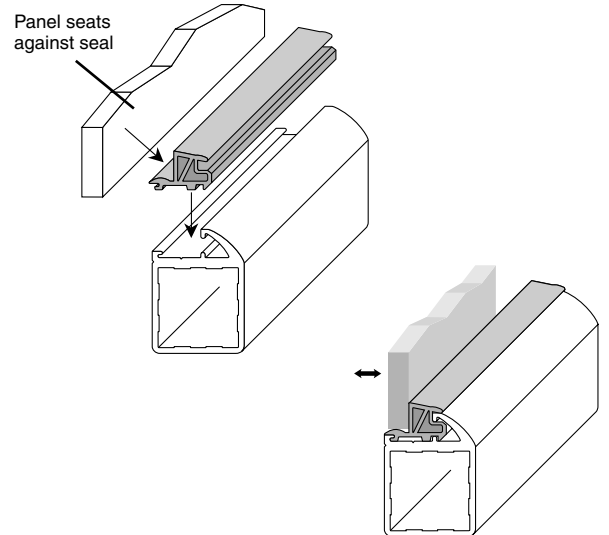
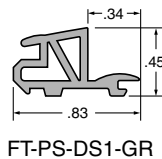
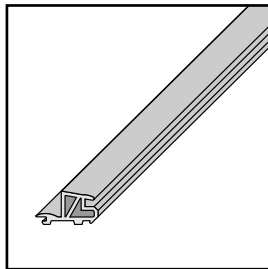

## Seal Bead

**FT-FDS-GZ-10-LX**

**FT-FDS-GZ-30-LX**

Used on FT-30T-FDS-10-tube to seal framed door against flange.

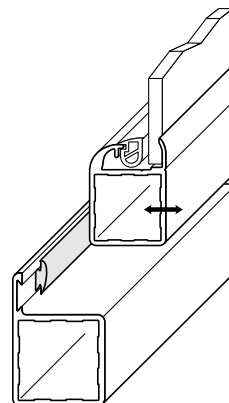
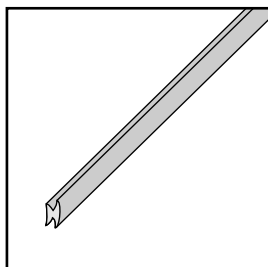

# Panel Mounting

## Mounting Block Kit FT-PMB-01-CLR FT-PMB-01-GR

Made from clear polycarbonate or glass reinforced gray polyamide, mounting blocks are used where easy panel removal is needed and an air tight seal is not a concern. Designed to be placed around the inside of the panel frame, mounting blocks can be used to support both vertical and horizontal panels, such as side panels and enclosure tops. Hardware included.

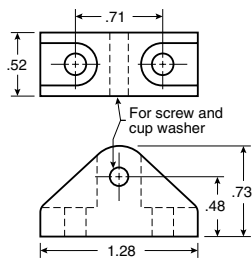
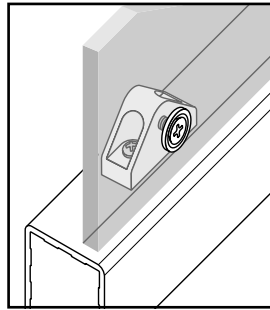

For additional panel mounting options, see pg. 42.

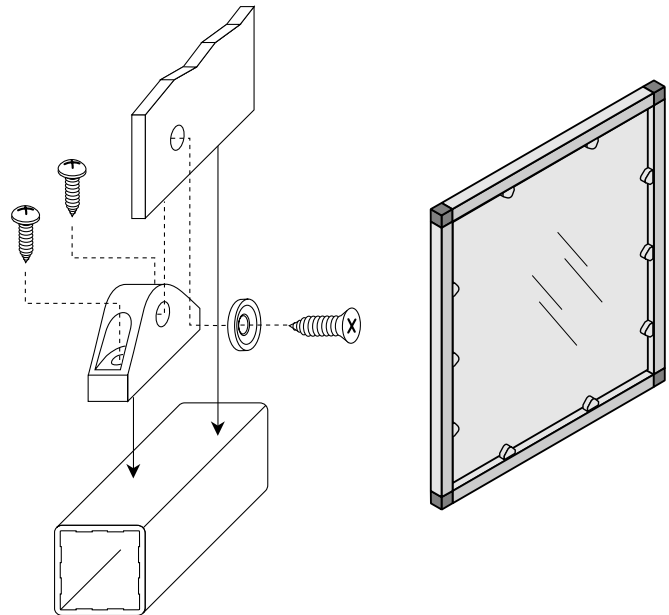

## One Sided Pop-In Panel Clamp FT-PMC1-GR

Nylon pop-in panel clamps are easy to install and permit removal of the panel. Hardware included. Panel thickness range: 3/16" to 3/8".

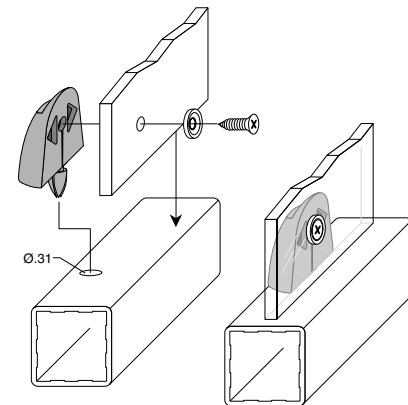
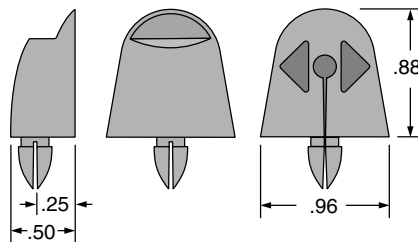

## Two Sided Pop-In Panel Clamp FT-PMC2-GR

Nylon pop-in panel clamps are easy to install and do not require holes to be drilled into the panel. Can be used to retain plastic and wire mesh panels. Hardware included. Panel thickness range: 3/16" to 3/8".

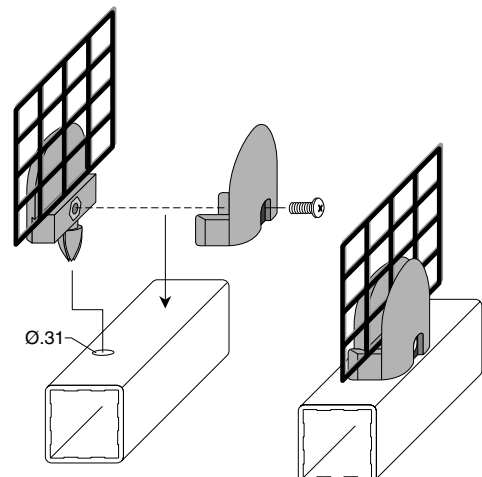
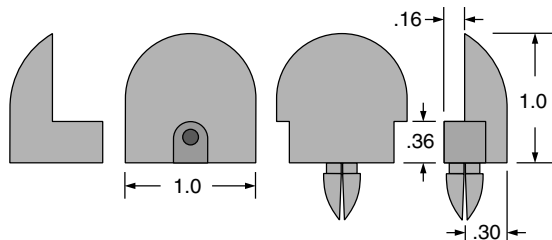

# Handles

## 15° Offset Thru Handle

**FT-HDL-1-GR** (Gray)  
 Made of high strength gray polyamide.  
 Ergonomic 15° offset.

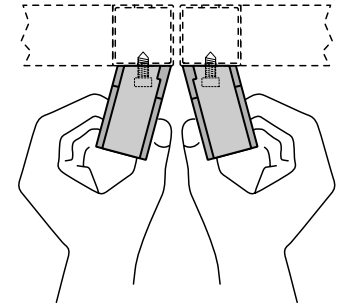
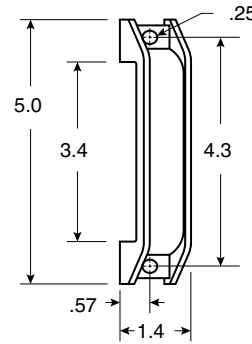
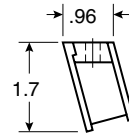
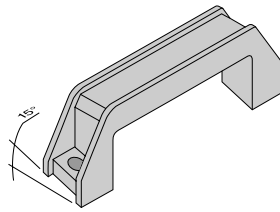

## 15° Offset Closed Handle

**FT-HDL-1-C-GR** (Gray)  
 Made of high strength gray polyamide.  
 The 15° offset and closed design  
 allows easy opening without pinched  
 fingers and scraped knuckles when  
 handles are mounted side by side on  
 adjacent doors.

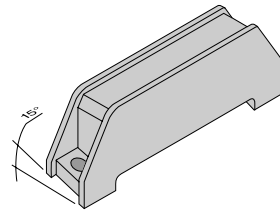

## Handle Cover

**FT-HDL-1-CAP-OR** (Safety Orange)

**FT-HDL-1-CAP-BK** (Black)

Handle cover fits both thru and closed offset  
 handles to aid in visibility and safety.

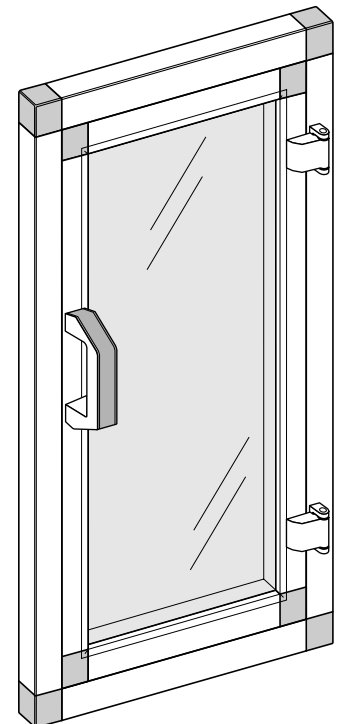
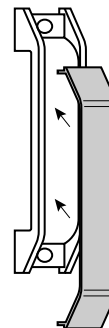
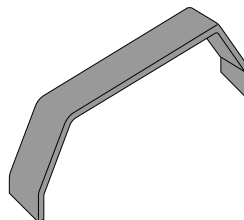

*For additional handles, see pg. 43*

## Door Closures

■ See page 26 for mounting details

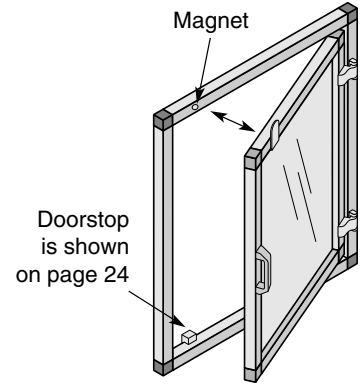

### Door Magnet Kit (outside mount)

#### FT-MAG-21-GR

Keeps framed doors closed. Magnet is mounted into Series 30 frame and reinforced polyamide catch is mounted on outside of Series 25 framed panel door. Hardware included.

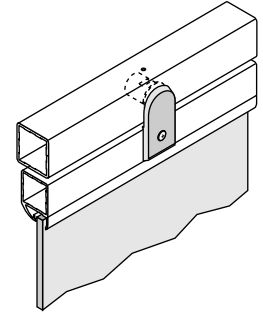
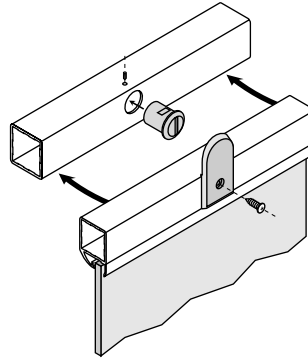
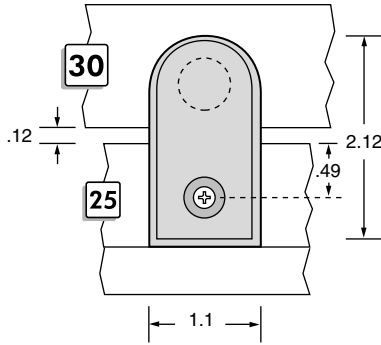

### Door Magnet Kit (inside mount)

#### FT-MAG-22-GR

Keeps framed doors closed. Magnet and reinforced polyamide support are mounted on inside of Series 30 frame and metal catch is mounted on inside of Series 25 framed panel door. Hardware included.

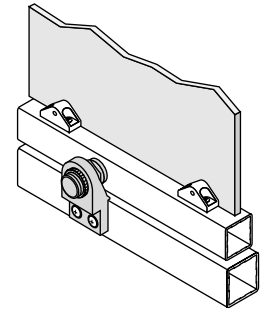
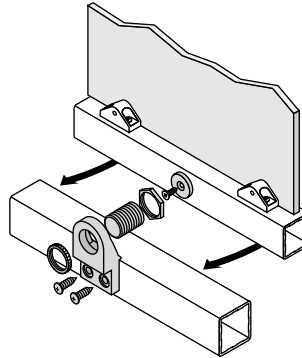
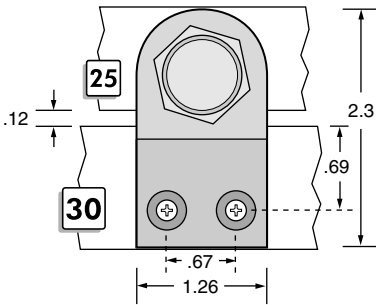

### Door Magnet Kit (bifold door outside mount)

#### FT-MAG-31-GR

Keeps framed doors closed. Magnet is mounted on Series 30 Bifold Track Tube and reinforced polyamide catch is mounted on outside of Series 25 framed panel door. Hardware included.

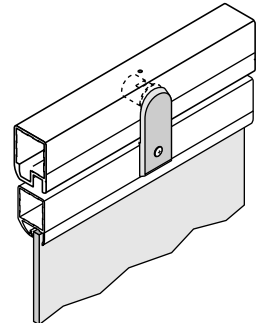
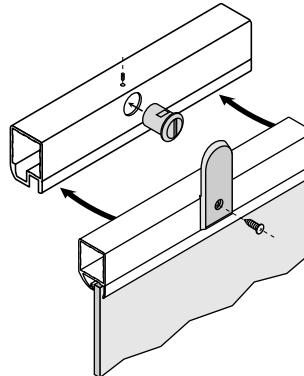
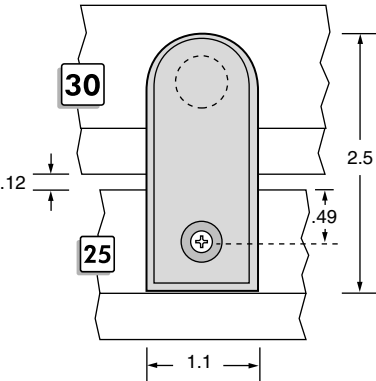

### Door Magnet Kit (inside mount)

#### FT-MAG-32

Keeps framed doors closed when doors are mounted directly onto machine frame. Magnet and stainless steel support are mounted on inside of machine frame and catch is mounted on inside of framed panel door. Hardware included.

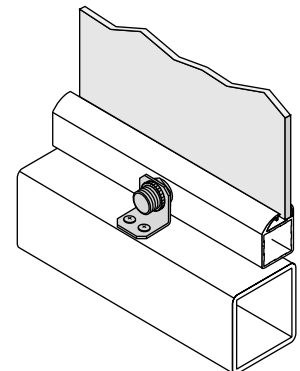
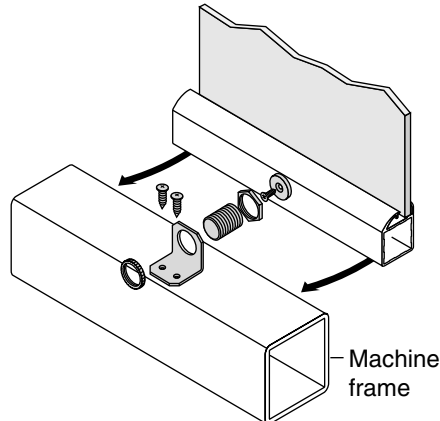
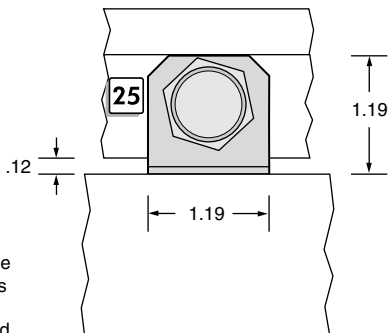

## Framed Door Compression Latch FT-FDLAT-02

Used with a Series 25 framed door and Series 30 outside frame. With a half turn of the handle, the door is latched tightly to the frame. Black powder coated metal handle. Requires two doorstops, FT-HDS-01-, page 24. All hardware is included. See page 26 for mounting details.

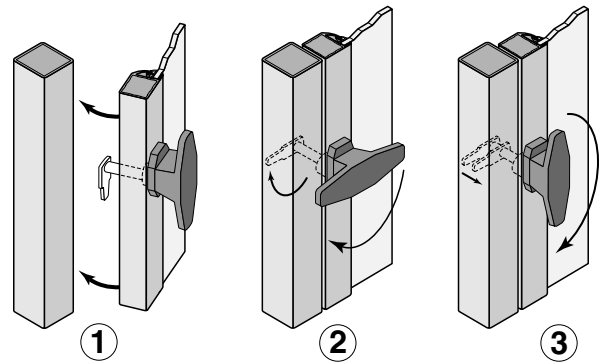
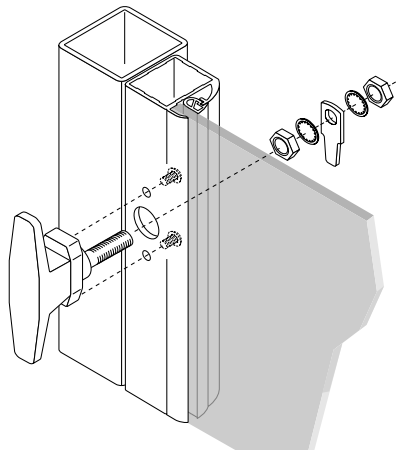

## Framed Door Latch FT-FDLAT-01

Nylon latch is used with a Series 25 framed door and Series 30 outside frame to provide a secure, flush closure. For use on standard, sealed frame and bifold doors.

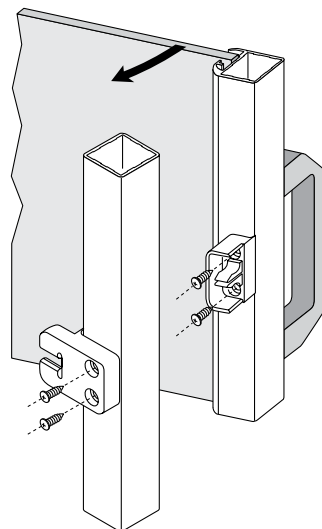
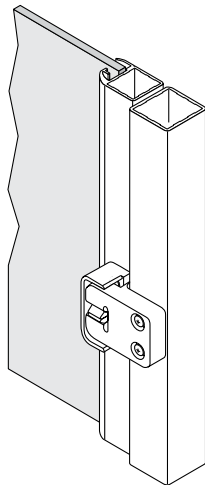

## Panel Door Latch FT-LAT-01

Plastic and anodized aluminum latch for unframed doors. Ergonomic latch is mounted into door panel. Handle rotates through 360° with click stops every 90°. Latch pawl engages panel seal tube.

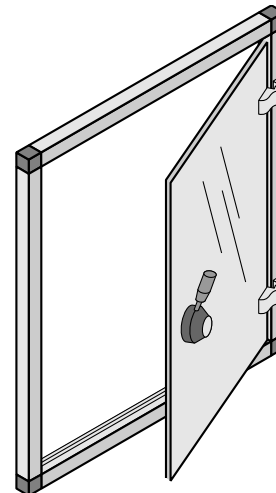
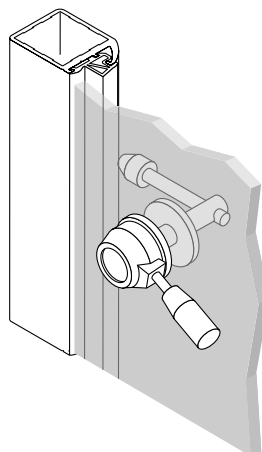

# FLEXTech™

## Hinges

■ Anodized aluminum in two finishes: Clear and Elox tint to match stainless steel

See page 26 for mounting details.

See page 29 for mounting hardware.

Sheet metal screws shown.

See page 24 for rivet nuts.

### Frame Hinge Mounting Kit

#### FT-HNG-21-AL-AN

Heavy duty aluminum hinge used to attach a framed panel door to a frame. Special shoulder bolt and lock washer included.

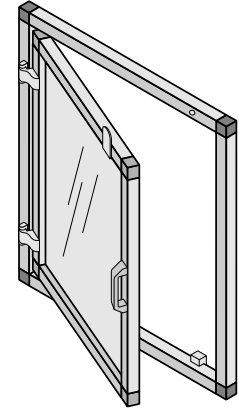
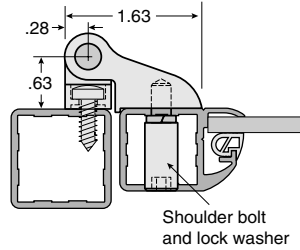
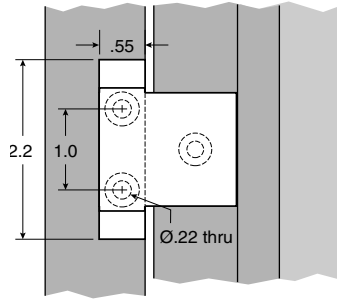
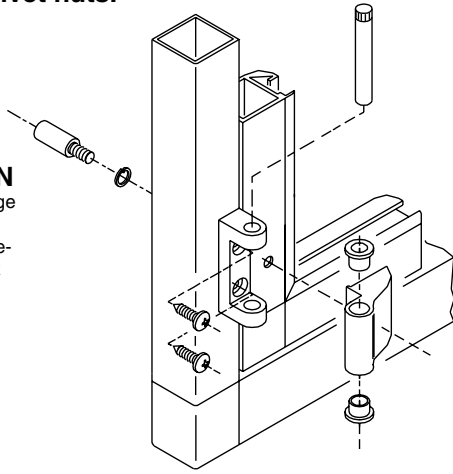

### Flush Hinge

#### FT-HNG-01-AL-AN

#### FT-HNG-01-AL-LX

Medium duty aluminum hinge used to connect bifold doors together or attach a framed panel door to a frame.

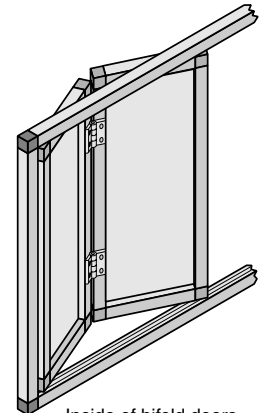
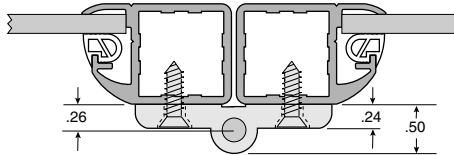
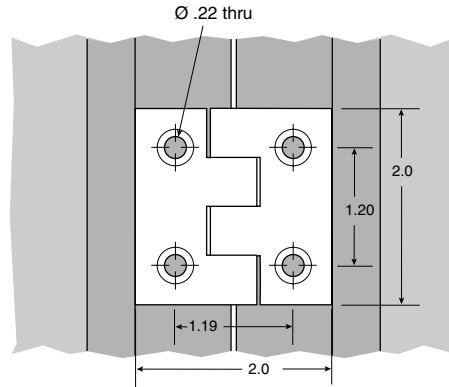
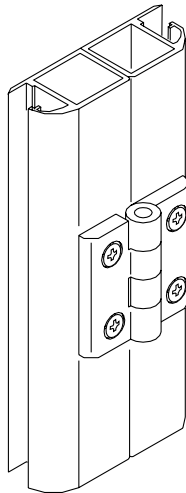

Inside of bifold doors showing flush hinges.

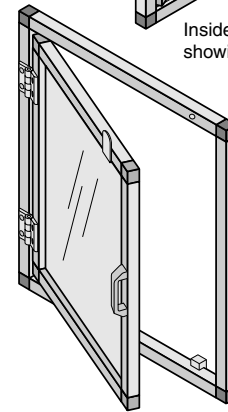

### Panel Door Hinge Kit

#### FT-HNG-22-AL-AN

#### FT-HNG-22-AL-LX

Heavy duty aluminum hinge used to attach an unframed door to a frame. Screw and plastic cup washer included.

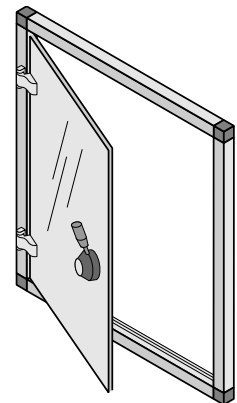
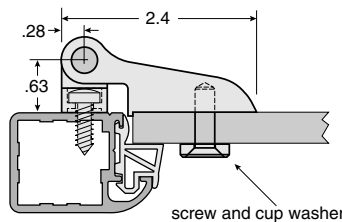
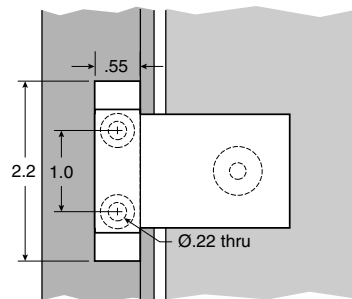
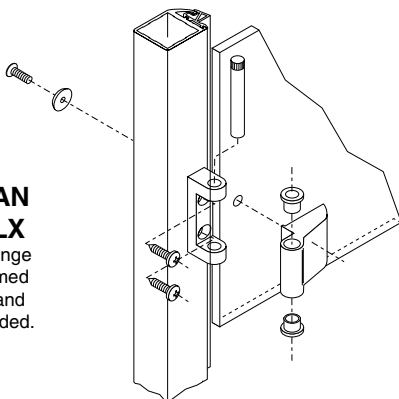



## Stainless Steel Continuous Hinge FT-HNG-02-SS

Made of 304 stainless steel.  
Available in 8 ft. lengths.

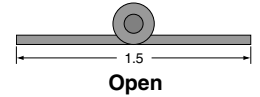
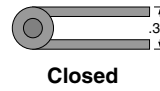
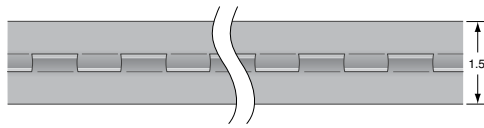

## Internal Hinge Pin Kit FT-PIN2

Steel pin is used with Internal Hinge Corner Joint to attach a framed panel door to a frame. Hinge pin, plastic bushing, and roll pin are included.

The hole in the Internal Hinge Corner Joint is positioned toward the outside of the structure. Since the socket location is offset, the Series 25 door panels will be flush with the Series 30 frame.

**Note:** Cannot be used with Framed Door Seal Tube (FT-30T-FDS-10-).

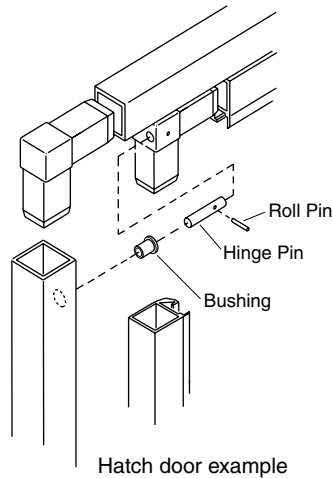

Hatch door example

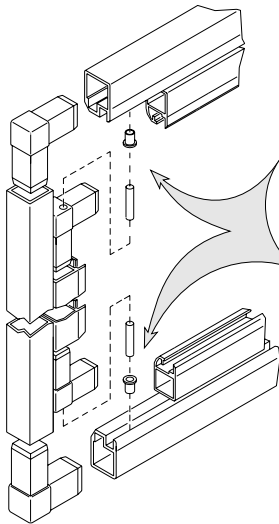
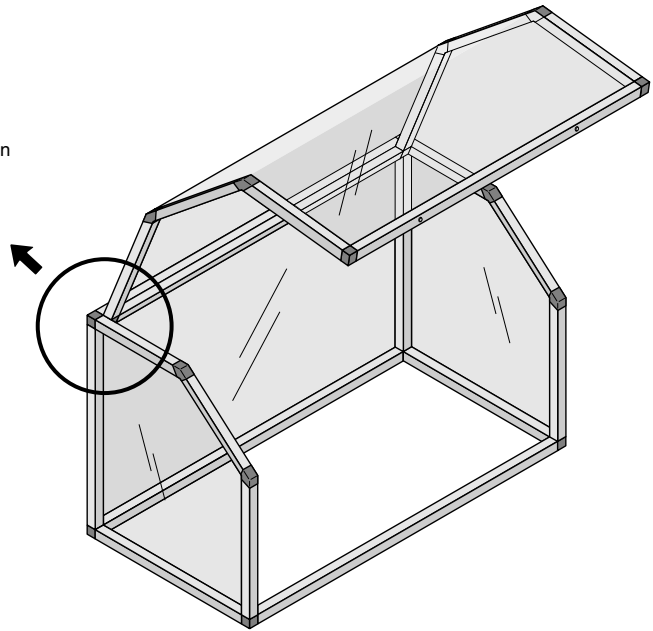

Bifold door example

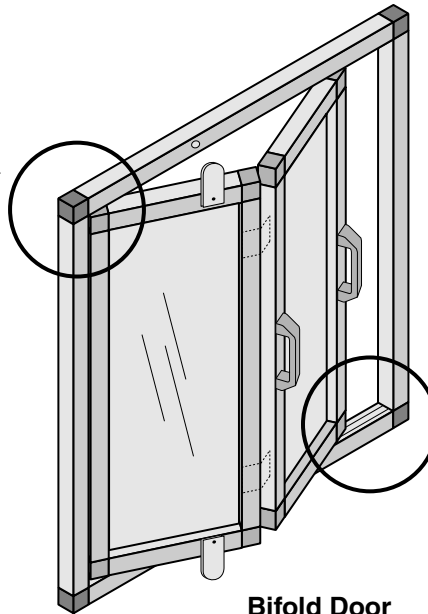

## Bifold Door Slide Pin FT-PIN1-DL

Acetal pin is used on the top and bottom sliding end of bifold doors. The pin slides in the track of the Sliding Track Tube and requires Internal Hinge Corner Joints (see page 13).

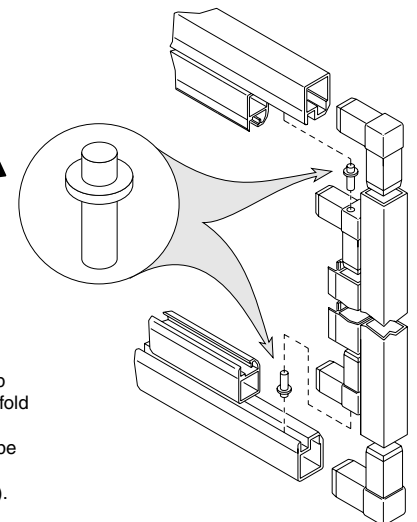

# Gas Springs

## FT-GS-

Gas springs are used on gull wing and hatch doors to assist in opening doors and keeping them in their open positions. Most doors require two gas springs so that the load on the springs and the door frame is balanced.

The ends of the springs have sockets which fit over a ball on the mounting brackets. This attachment allows some flexibility in mounting locations such that the brackets do not have to be directly in line with each other. Two mounting bracket types are available. Gas springs are always mounted rod end down.

Available stock sizes should work for most applications, but other sizes and spring forces are available. Please call our Engineering Services Group for assistance in sizing and locating gas springs.

### FT-GS-1220

- Extended: 12 in.
- Compressed: 8.5 in.
- Stroke: 3.5 in.
- Spring Force: 20 lbs.

### FT-GS-1240

- Extended: 12 in.
- Compressed: 8.5 in.
- Stroke: 3.5 in.
- Spring Force: 40 lbs.

### FT-GS-2020

- Extended: 20 in.
- Compressed: 12 in.
- Stroke: 8 in.
- Spring Force: 20 lbs.

### FT-GS-2040

- Extended: 20 in.
- Compressed: 12 in.
- Stroke: 8 in.
- Spring Force: 40 lbs.

### FT-GS-2080

- Extended: 20 in.
- Compressed: 12 in.
- Stroke: 8 in.
- Spring Force: 80 lbs.

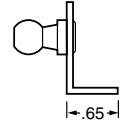
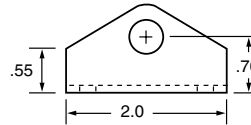
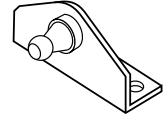
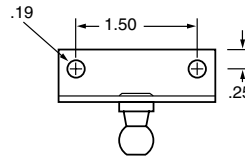
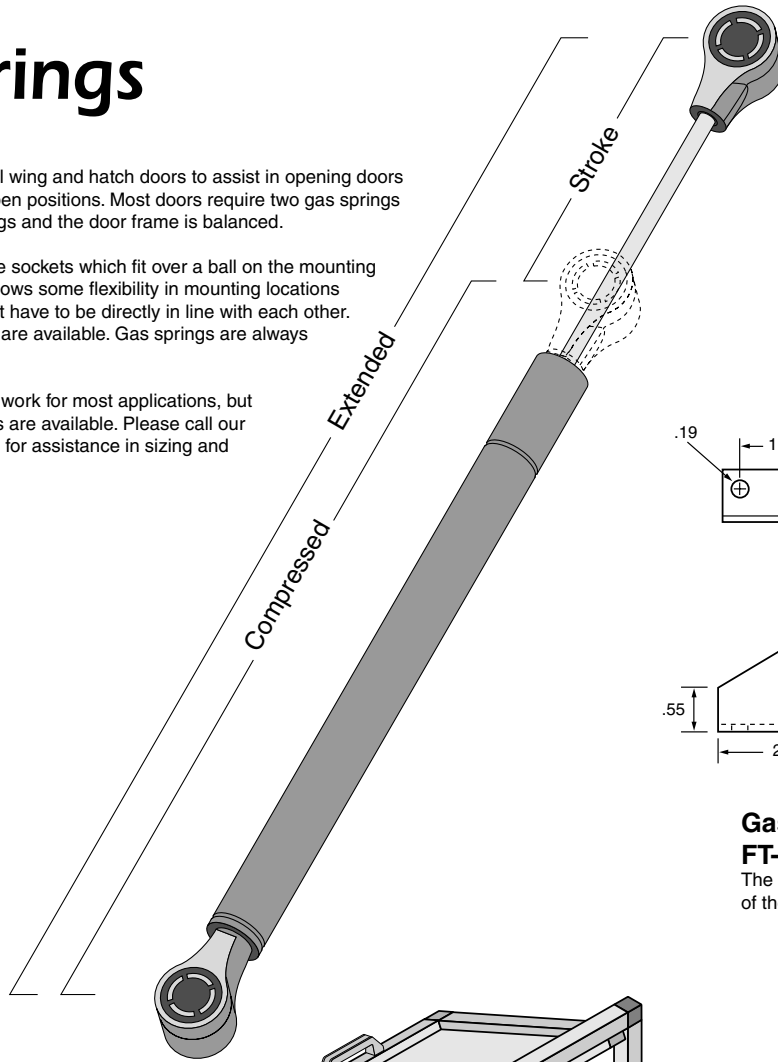

## Gas Spring Mounting Bracket

### FT-GSMB-1

The right angle bracket is mounted on the back side of the tube.

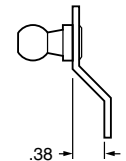
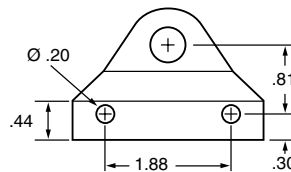
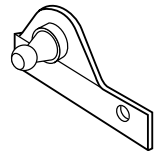
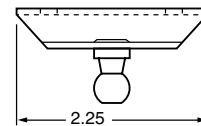
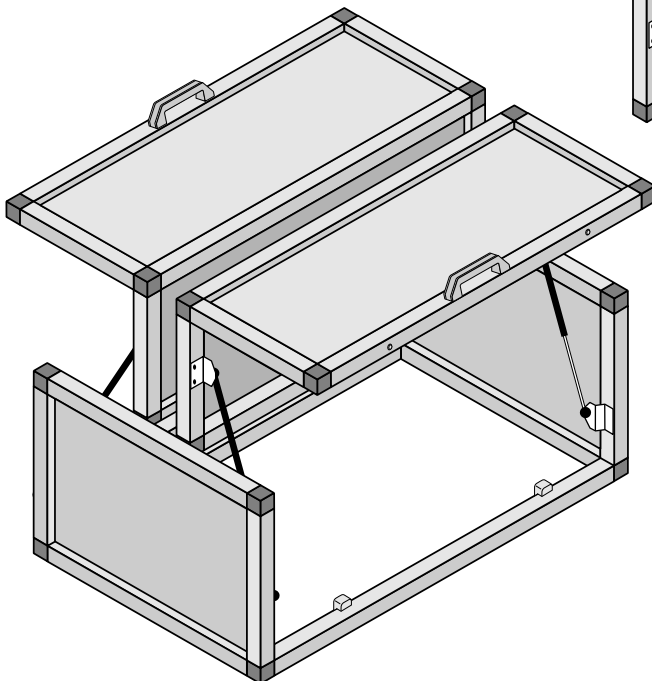
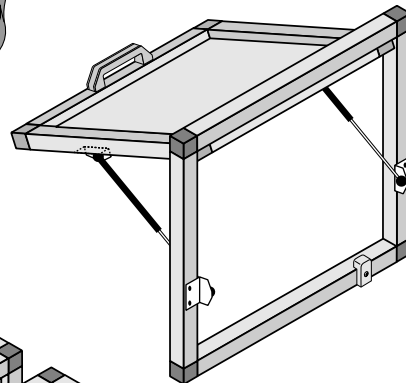

## Flush Mount Gas Spring Mounting Bracket

### FT-GSMB-6

The flush mount bracket is mounted on the side of the tube. Most commonly used with gull wing doors. Requires 1/4" spacing between door and frame.

# Braces

**NEW**

## FT-25-BRC-03 90° Angle Brace

Aluminum support brace is used to support 90° corners. Mounting screws included.

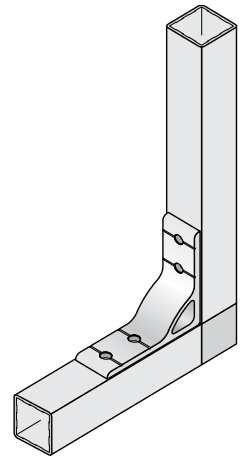
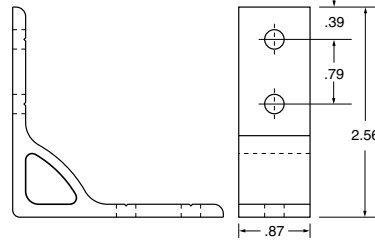
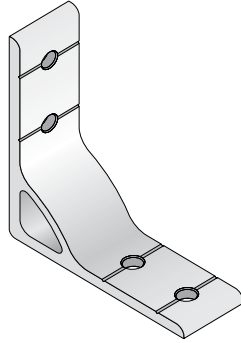

**NEW**

## FT-25-BRC-04 45° Angle Brace

Aluminum support brace is used to support 45° corners commonly used on gull wing doors. Mounting screws included.

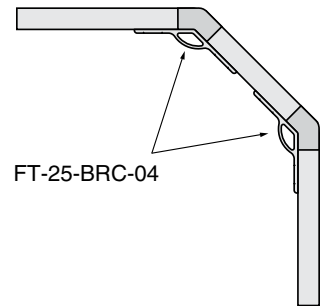
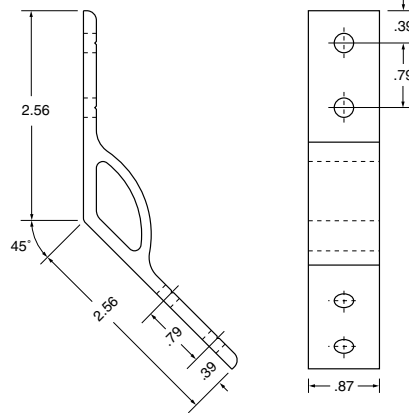
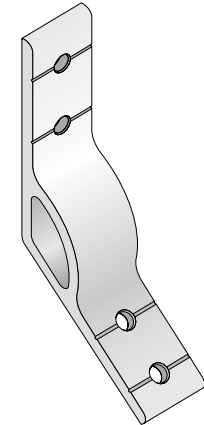

FT-25-BRC-04

## Angle Brackets

### FT-30-SUP-01

### FT-30-SUP-02

Stainless steel angle brackets are used as added corner support or to attach tubing or frames to other equipment. Hardware not included.

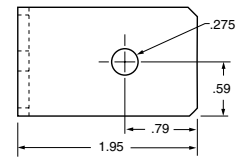
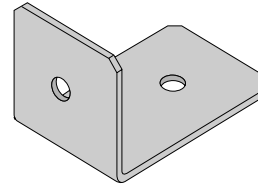
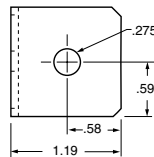
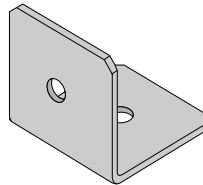
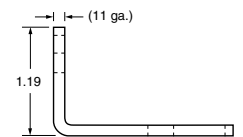
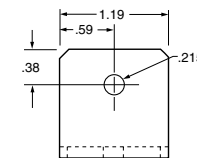
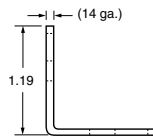
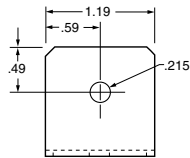

## Joining Plate

### FT-25-PLT

### FT-30-PLT

Stainless steel joining plates are used to connect adjoining tubes together. Hardware not included.

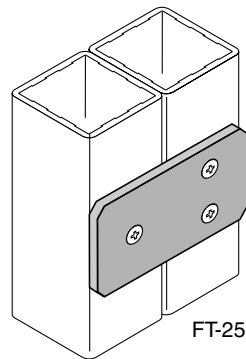

FT-25-PLT

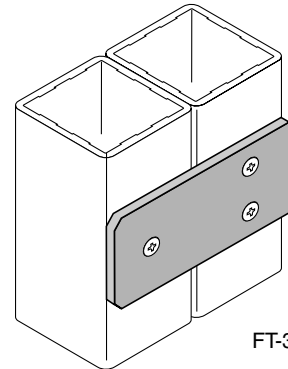

FT-30-PLT

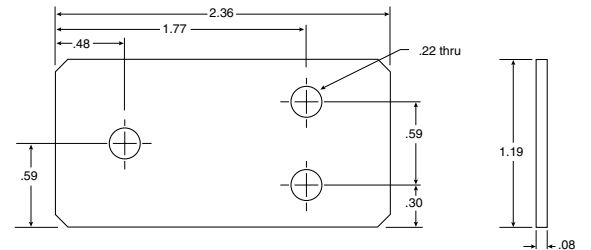
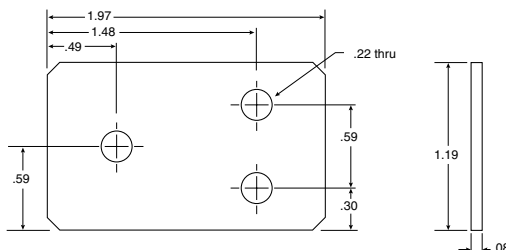

# FlexTech Accessories

## Door Stop

**FT-HDS-01-GR** (Gray)  
Reinforced polyamide door stop is typically mounted on the bottom of the Series 30 frame. Mounting screw included.

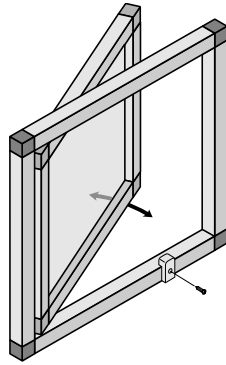
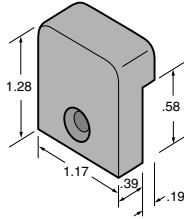

## Threaded Tube Ends

**FT-END-01-BK** (M16 thread)

**FT-END-02-BK** (5/8-11 thread)

Black reinforced polyamide tube ends insert tightly into Series 30 tubes and accept M16 or 5/8-11 threaded adjustable levels.

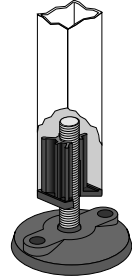
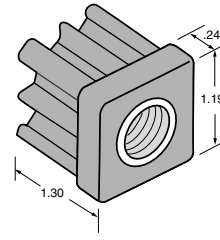

## Shoulder Bolts

**FT-FAST-01** (for Series 25 tube)

**FT-FAST-02** (for Series 30 tube)

Plated steel bolts are used to mount Series 25 and Series 30 tubes to other tubes or frames. Lock washer included.

Shoulder bolt and lock washer

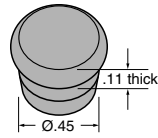
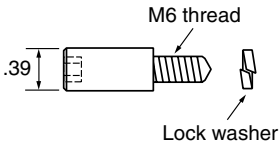
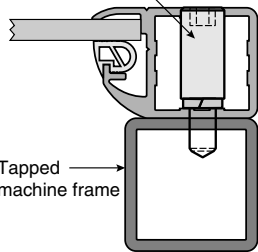

**Bumper Cap**  
**FT-PCP-GR**

Gray plastic caps are used on the bottom of gull wing doors to protect the frame from marring.

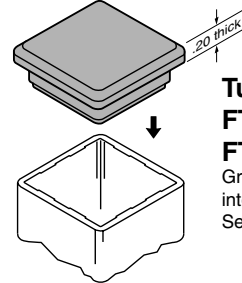

**Tube Caps**  
**FT-25-CAP-GR**  
**FT-30-CAP-GR**

Gray plastic caps fit tightly into the ends of Series 25 or Series 30 tubes.

# Valu Guard Assembly Accessories

## Rivet Nuts

**11044** (10-32 thread for handles and accessories)

**11045** (M6 thread for FT-FAST- shoulder bolts)

Plated steel, threaded fastener is inserted from the front side of a tube. Provides a more secure fastening method than sheet metal screws.

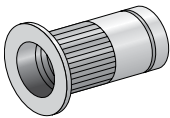

## Pop Rivets

**14037**

Used to secure joints and adapters to tubes. Aluminum with steel mandrel.

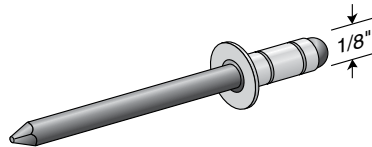

## Panel

**Cleaning Solution**  
**VG-1004**

Keep your panels clean and static free. Recommended for cleaning and polishing plastic panels. Will not cause crazing, cracking or scratches that can result from the use of glass cleaners or all-purpose cleaners.



## Rivet Nut Installation Tool

**VG-1001**

Used to install rivet nuts. Includes mandrels for installing 8-32, 10-24 and 10-32 rivet nuts.

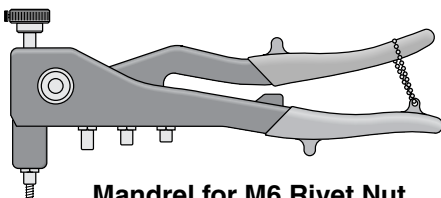

## Pop Rivet Installation Tool

**VG-1003**

Used to install pop rivets.

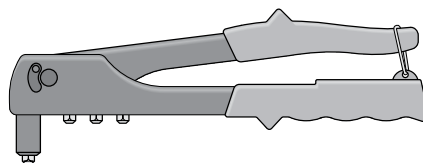

## Mandrel for M6 Rivet Nut

**VG-1002**

Used with rivet nut installation tool to install M6 rivet nuts.

# Quick Pick Guard Selector

for machine base mounted guards

## Step 1:

Select guard type.

Panel

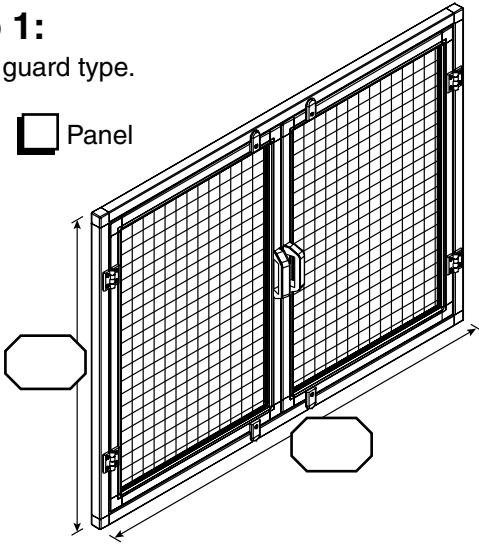

L-Shaped (2 sides)

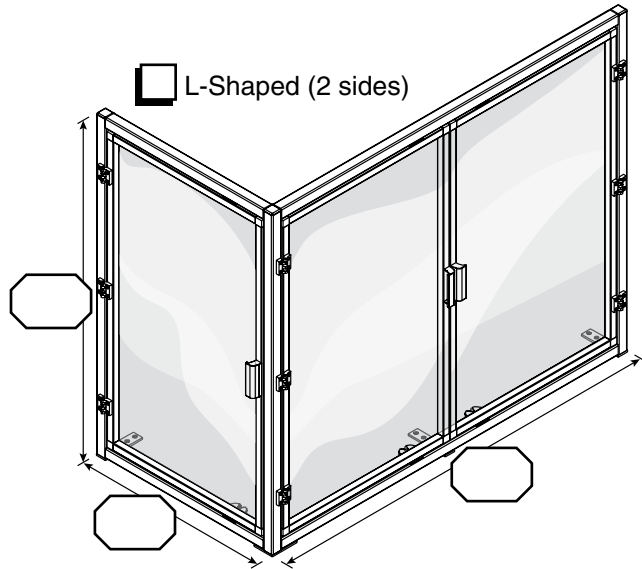

U-Shaped (3 sides)

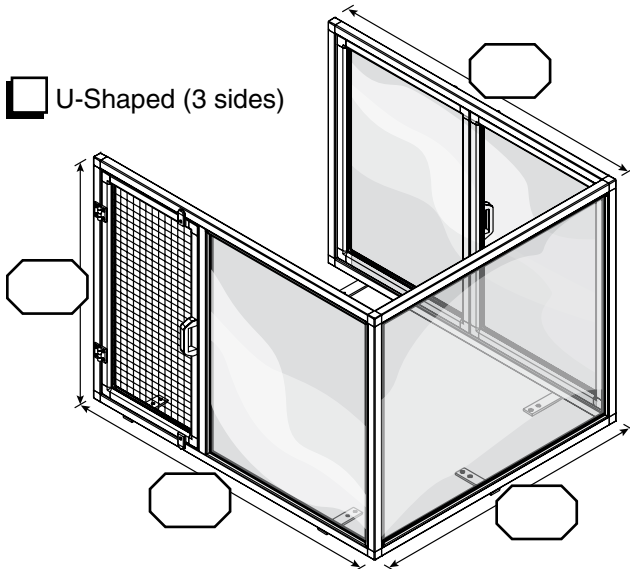

Full enclosure (4 sides)

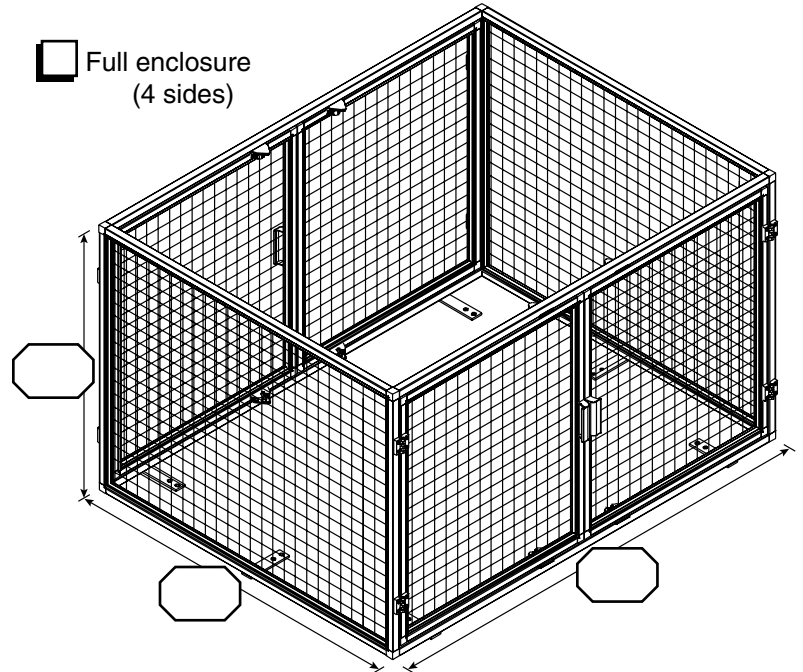

## Step 2:

Select frame material.

Aluminum

Stainless steel

## Step 3:

Select panel material.

Wire mesh

Polycarbonate

Acrylic

## Step 4:

Fill in the required dimensions and door locations and fax this page us. Toll free fax: 1-866-447-6587. We will submit a quotation to complete your project.

Form submitted by: \_\_\_\_\_ Company: \_\_\_\_\_ Phone: \_\_\_\_\_

# Hardware Mounting Details

See page 29 for the hardware to be used with these components.

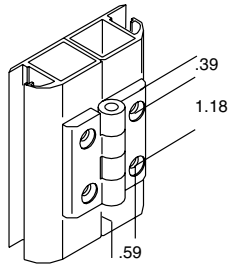

**Flush Hinge**  
FT-HNG-01-AL-

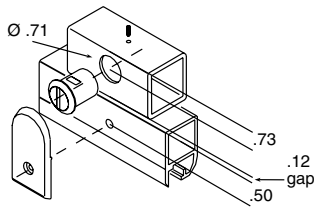

**Door Magnet**  
FT-MAG-21-

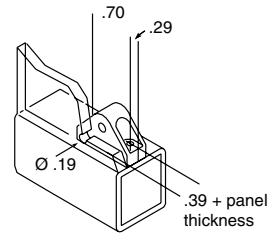

**Mounting Block for Square Tubing**  
FT-PMB-01-

#8 x 3/8 sheet metal screw  
or Ø1/8 x 3/8 pop rivet  
(may require shim on insert tool)

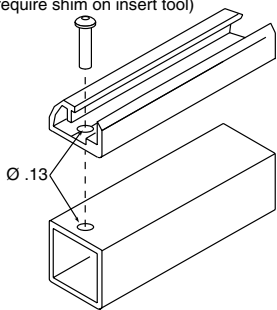

**Tube Adapters**  
FT-25C-  
FT-30C-

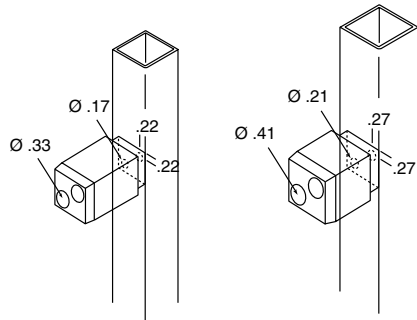

**Internal Connectors**  
FT-25-PA-PLG      FT-30-PA-PLG

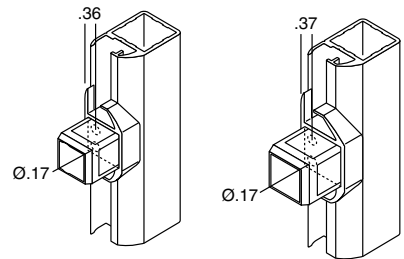

**Miterless Tee Connectors**  
FT-25-PA-MT      FT-30-PA-MT

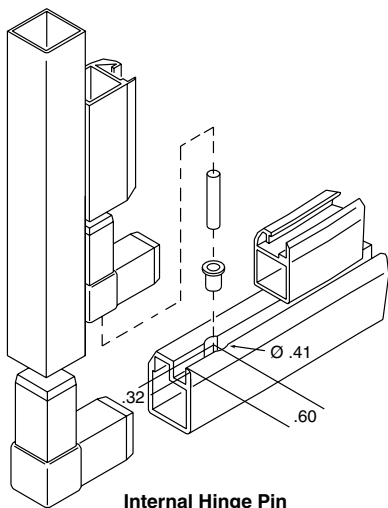

**Internal Hinge Pin**  
FT-PIN2

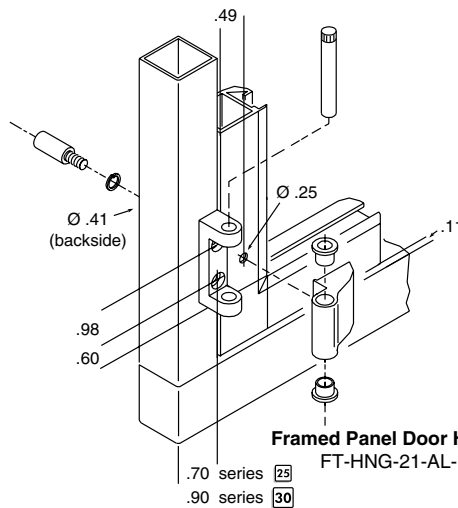

**Framed Panel Door Hinge**  
FT-HNG-21-AL-  
.70 series [25]  
.90 series [30]

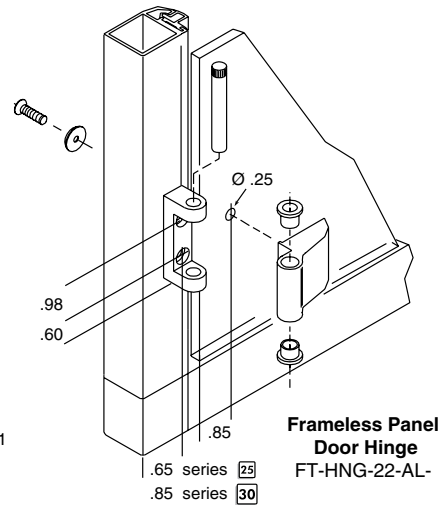

**Frameless Panel Door Hinge**  
FT-HNG-22-AL-  
.65 series [25]  
.85 series [30]

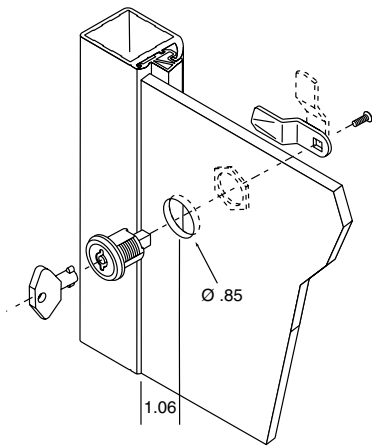

**Panel Door Lock/Latch**  
FT-LCK-01/FT-LAT-02

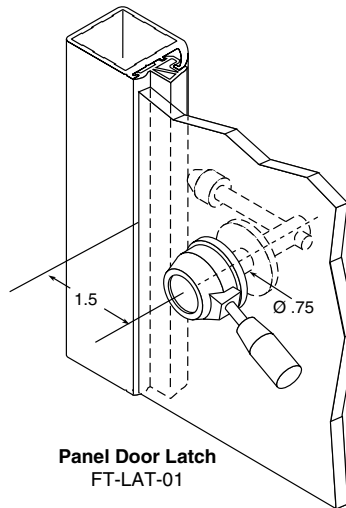

**Panel Door Latch**  
FT-LAT-01

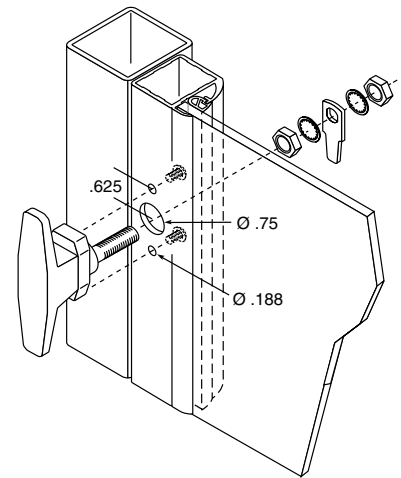

**Framed Door Compression Latch**  
FT-FDLAT-02

# Anchoring to Other Frames and Bases

FlexTech enclosures can be anchored to frames and bases by several means:

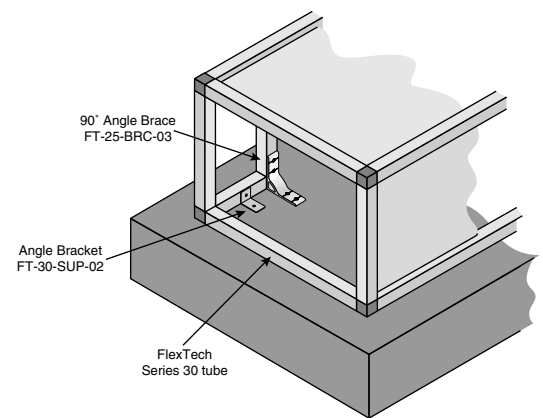
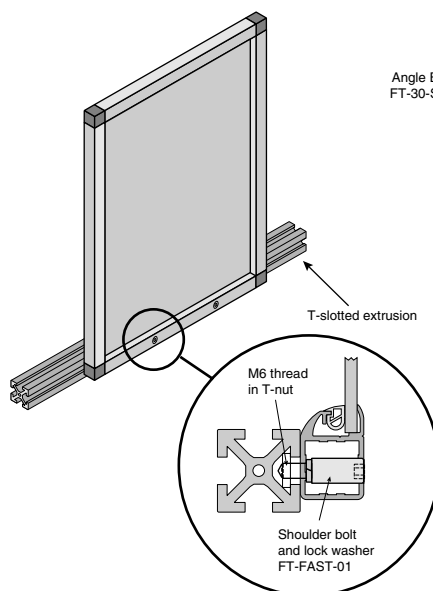
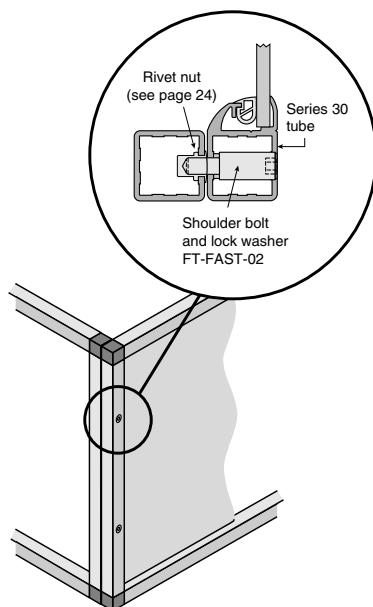

**Attach To Any Frame!**

# Typical Bill of Materials

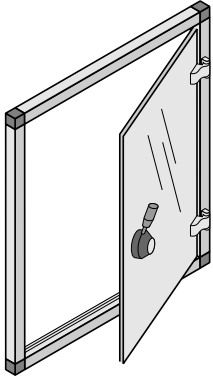

**Unframed Panel Door Parts:**

Description	Part No.	Cut to Size	Quantity
Tube	FT-30T-PS-10-LX	✓	4
Seal	FT-PS-DS1-GR	✓	4
Corner joint	FT-30-PA-J2-GR		4
Hinge	FT-HNG-22-AL-LX		2
Latch	FT-LAT-01		1
Panel	1/4" material	✓	1

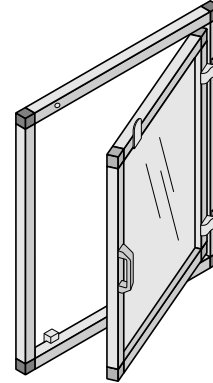

**Framed Door Parts:**

Description	Part No.	Cut to Size	Quantity
Outer frame tube	FT-30T-10-LX	✓	4
Outer corner joint	FT-30-PA-J2-GR		4
Door panel tube	FT-25T-PF-10-LX		4
Panel glazing bead	FT-PF-GZ1-GR	✓	4
Door panel joint	FT-25-PA-J2M-GR		4
Hinge	FT-HNG-21-AL-AN		2
Closure	FT-MAG-21-GR		1
Door stop	FT-HDS-01-GR		1
Handle	FT-HDL-1C-GR		1
Handle cover	FT-HDL-1-CAP-OR		1
Panel	1/4" material	✓	1

**Single Bifold Door Parts:**

Description	Key	Part No.	Cut to Size	Quantity
Top and bottom outer frame tube	A	FT-30T-PT-10-AN	✓	2
Left and right outer frame tube	B	FT-30T-10-AN	✓	2
Outer frame corner joint	C	FT-30-PA-J2-GR		4
Door panel tube (both panels)	D	FT-25T-PF-10-AN	✓	8
Panel glazing bead	E	FT-PF-GZ1-GR	✓	8
Inside panel corner joint	F	FT-25-PA-J2M-GR		4
Top hinged corner joint	G	FT-25-PA-J2MRH-GR		1
Bottom hinged corner joint	H	FT-25-PA-J2MLH-GR		1
Top sliding corner joint	I	FT-25-PA-J2MLH-GR		1
Bottom sliding corner joint	J	FT-25-PA-J2MRH-GR		1
Internal hinge	K	FT-PIN2		2
Slide pin	L	FT-PIN1-DL		2
Flush hinge	M	FT-HNG-01-AL-AN		2
Closure	N	FT-MAG-31		2
Handle	O	FT-HDL-1-GR		2
Handle cover	P	FT-HDL-1-CAP-OR		2
Panel	Q	1/4" material	✓	2

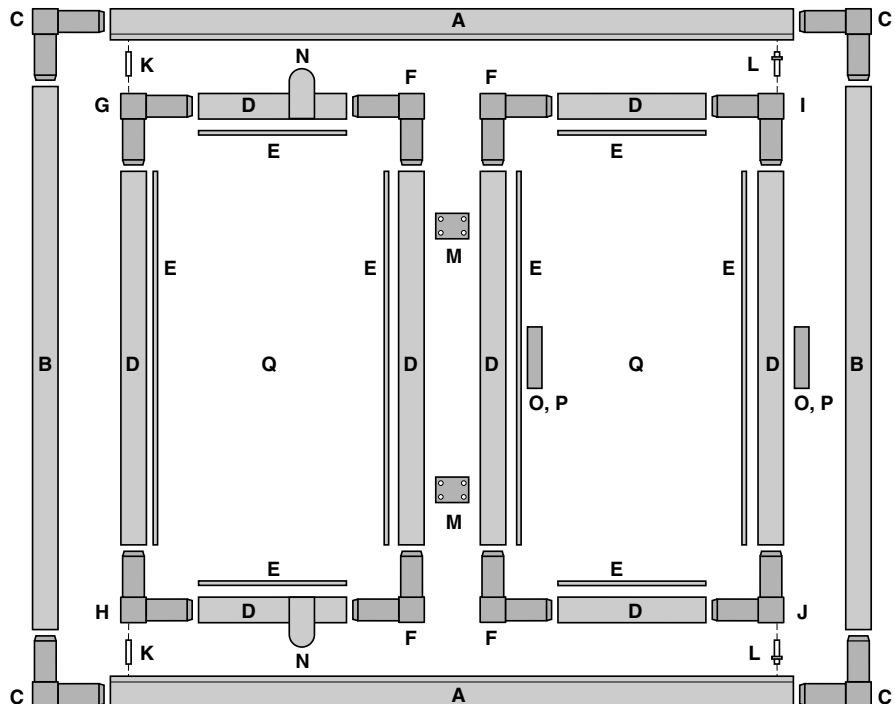
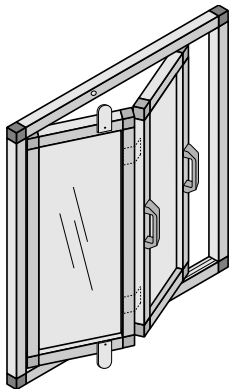



# Hardware Table

The following is a table of fasteners used with FlexTech components.  
See page 24 for Assembly Accessories.

Description	Page No.	Hardware Included in Kit	Additional Hardware Required
Internal Tube Connectors (FT-25-PA-PLG)	13	No Kit Available	#8 x 3/4" Sheet Metal Screw
Internal Tube Connectors (FT-30-PA-PLG)	13	No Kit Available	#10 x 3/4" Sheet Metal Screw
Miterless Tee Connectors (FT-25-PA-MT)	13	No Kit Available	#8 x 1" Sheet Metal Screw
Miterless Tee Connectors (FT-30-PA-MT)	13	No Kit Available	#8 x 1" Sheet Metal Screw
Internal Corner Adapters (FT-25-ADP-01-, FT-30-ADP-01-)	14	(2) #4 x 3/8" Flat Head Sheet Metal Screws	None Required
90 Degree Side Adapter (FT-25-ADP-R1-)	14	(2) #4 x 3/8" Flat Head Sheet Metal Screws	None Required
45 Degree Side Adapter (FT-25-ADP-R2-)	14	(2) #4 x 3/8" Flat Head Sheet Metal Screws	None Required
Panel Mounting Blocks (FT-PMB-01-)	16	(2) #8 x 5/8" Pan Head Sheet Metal Screws, (1) #8 x 3/4" Flat Head Sheet Metal Screw, and (1) Panel Mounting Washer	None Required
One Sided Pop-In Panel Clamp (FT-PMC1-)	16	(1) #8 x 1/2" Flat Head Sheet Metal Screw, and (1) Panel Mounting Washer	None Required
Tubing Adapters (FT-25C-,-30C-)	9	No Kit Available	1/8" dia. x 3/8" long Standard Aluminum or Steel Pop Rivets
Flush Hinge (FT-HNG-01-)	20	No Kit Available	10-32 x 5/8" Flat Head Machine Screws with Rivet Nut Inserts
Frame Hinge Kit (FT-HNG-21-)	20	Special M6 Shoulder Bolt (FT-FAST-01) with Lock Washer	(2) 10-32 x 3/4" Pan Head Machine Screws with Rivet Nut Inserts
Panel Door Hinge Kit (FT-HNG-22-)	20	(1) M6 Screw with Panel Washer	(2) 10-32 x 3/4" Pan Head Machine Screws with Rivet Nut Inserts
Internal Hinge Pin Kit (FT-PIN2)	21	Includes Pin, Bushing and Roll Pin	None Required
Gas Spring Mounting Brackets (FT-GSMB-1,-6)	22	No Kit Available	10-32 x 3/4" Pan Head Machine Screws with Rivet Nut Inserts
Door Magnet Kit (FT-MAG-21-,-31-)	18	#10 x 3/4" Pan Head Sheet Metal Screw and (1) 10-32 x 1/2" Set Screw	None Required
Door Magnet Kit (FT-MAG-22-)	18	(2) #10 x 3/4" Pan Head Sheet Metal Screws and (1) #4 x 3/8" Flat Head Sheet Metal Screw	None Required
Door Magnet Kit (FT-MAG-32-)	18	(2) #8 x 5/8" Pan Head Sheet Metal Screws and (1) #4 x 3/8" Flat Head Sheet Metal Screw	None Required
Framed Door Latch (FT-FDLAT-01)	19	(4) #10 x 3/4" Pan Head Sheet Metal Screws	None Required
Door Stop (FT-HDS-01-)	24	#10 x 3/4" Flat Head Sheet Metal Screw	None Required
Door Handles (FT-HDL-1-,-1C-)	Option 1 17	No Kit Available	#10 x 3/4" Pan Head Sheet Metal Screw
	Option 2	No Kit Available	10-32 x 3/4" Pan Head Machine Screw w/Washer and Rivet Nut Insert
90 Degree Angle Brace (FT-25-BRC-01)	23	(4) #10 x 3/4" Pan Head Sheet Metal Screws	None Required
45 Degree Angle Brace (FT-25-BRC-02)	23	(4) #10 x 3/4" Pan Head Sheet Metal Screws	None Required
Joining Plates (FT-25-PLT, FT-30-PLT)	23	No Kit Available	10 x 3/4" Pan Head Sheet Metal Screw
Angle Brackets (FT-30-SUP-01,-02)	23	No Kit Available	10 x 3/4" Pan Head Sheet Metal Screw

# SpeedFrame™

## Machine Guarding and Safety Enclosure System

The SpeedFrame System is a simple, economical tube and joint system used to fabricate safety enclosures for machinery. Choose from aluminum or stainless steel tubes and cast aluminum or plastic joints for applications ranging from general industrial framing to sanitary pharmaceutical enclosures.

### Easy, Economical Assembly

Assemble frames using a soft faced mallet to hammer in corner joints. Attach panels and hardware using simple hand and power tools. No welding, grinding or time consuming cleanup.

Build  
Stainless Steel  
Guarding with  
No Welding!

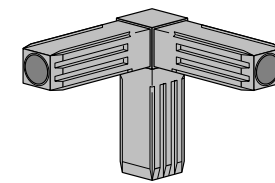

Steel Reinforced  
Plastic Corner  
Joints

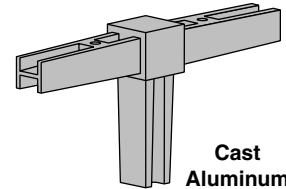

Cast  
Aluminum  
Corner  
Joints

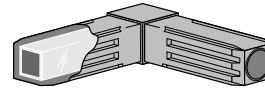

### Features

- ◆ Aluminum or stainless steel .050" wall tubes.
- ◆ Black die cast aluminum or steel reinforced plastic joints.
- ◆ All the hinges, handles, latches and other accessories you need.

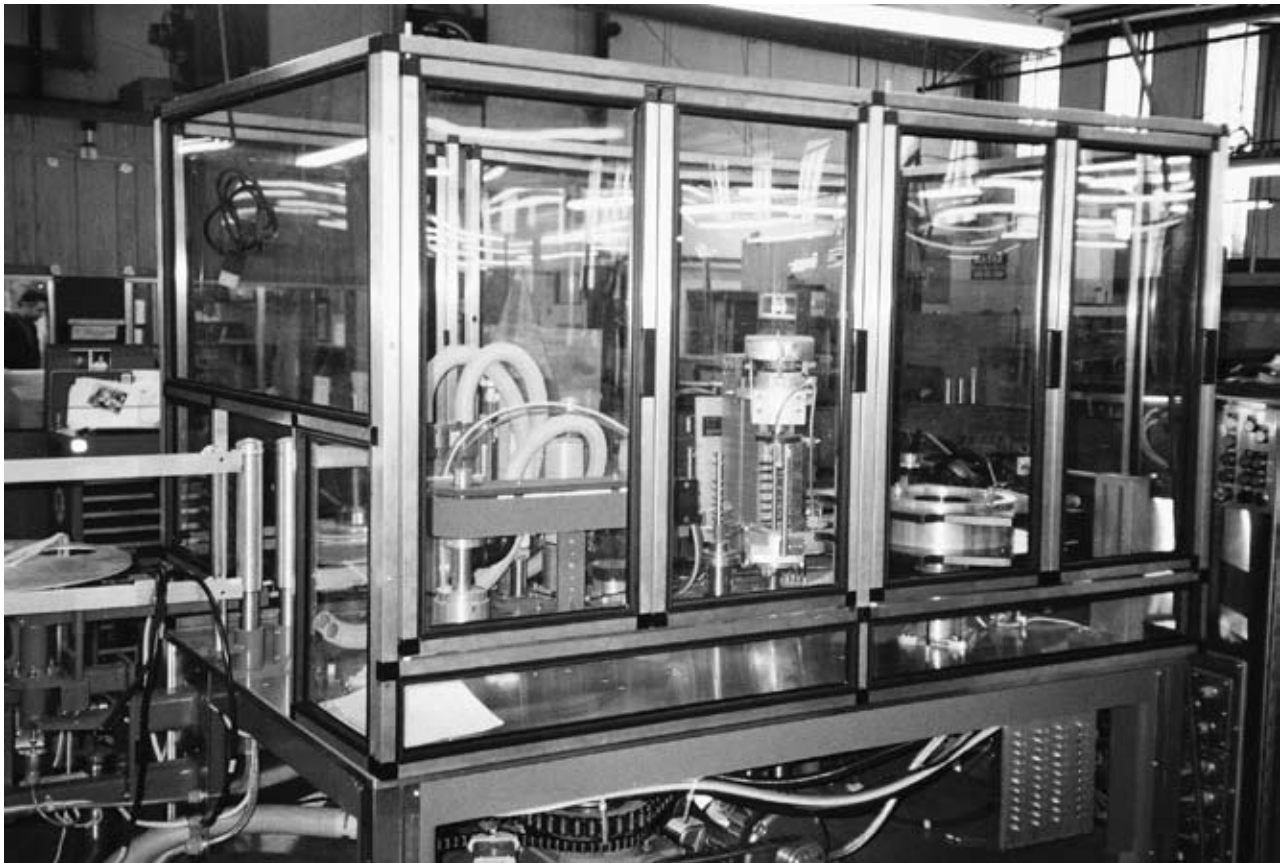

*This packaging machine enclosure uses two bifold doors to access nearly all of the enclosed machinery.*



*Unframed panel doors on this SpeedFrame enclosure provide economical machinery access.*

### ***Use SpeedFrame if you:***

- ◆ Need safety barriers on your equipment.
- ◆ Have corrosive washdown environments requiring a stainless steel structure.

### ***Satisfied customers include:***

- ◆ Pharmaceutical companies requiring stainless steel safety enclosures.
- ◆ Meat packagers using caustic washdown solutions.
- ◆ Industrial companies requiring fast and economical assembly of machine enclosures.



SpeedFrame

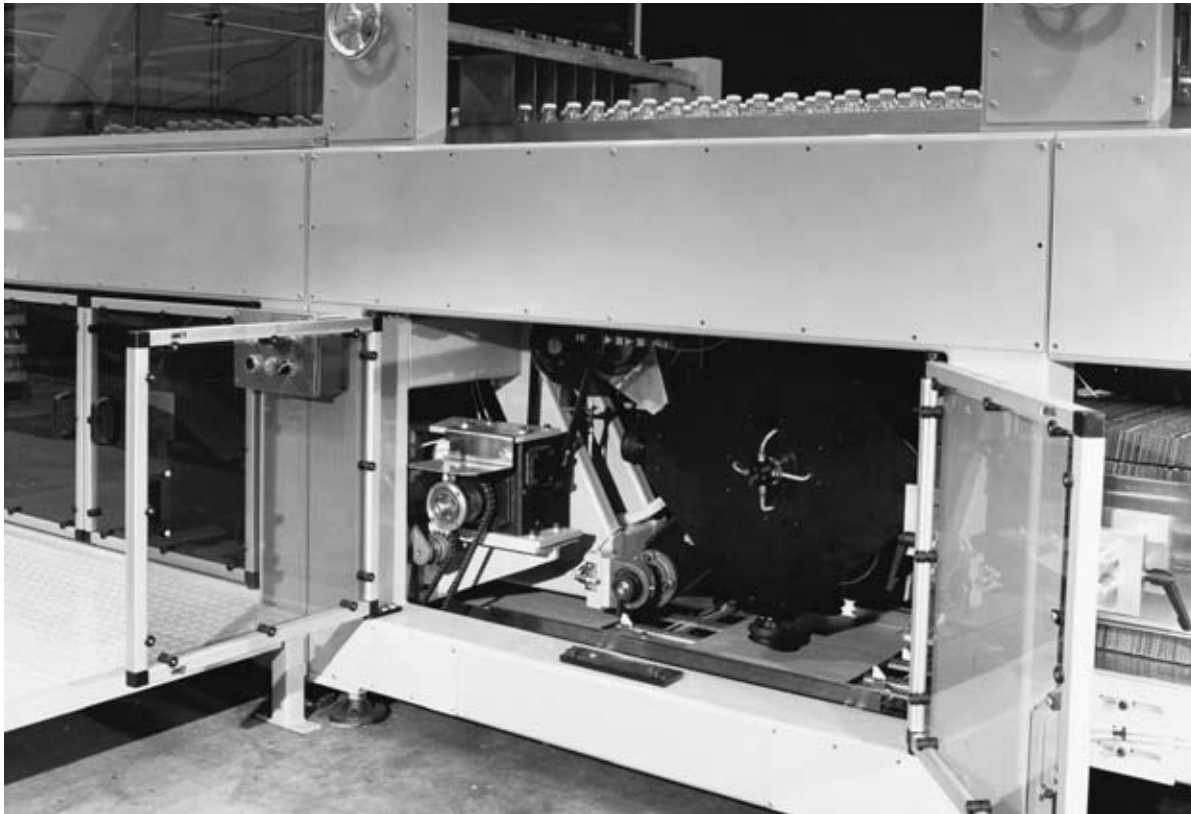

*These framed doors are attached directly to this packaging machine frame.*

# Typical Applications

Ideal for Washdown Areas!

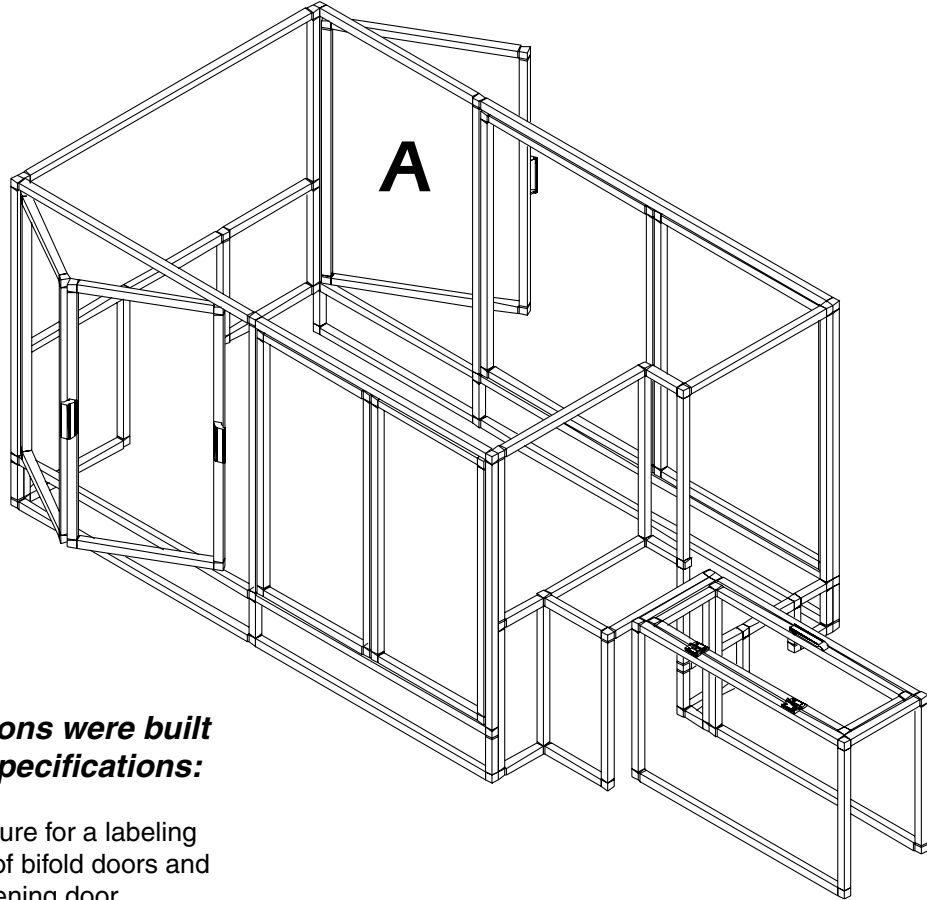

*These typical applications were built by us from customer specifications:*

**A** This stainless steel enclosure for a labeling machine includes three sets of bifold doors and an infeed cover with a top opening door.

**B** The three sets of large double doors on this stainless steel enclosure for a consumer products manufacturer allow nearly complete access to their machine.

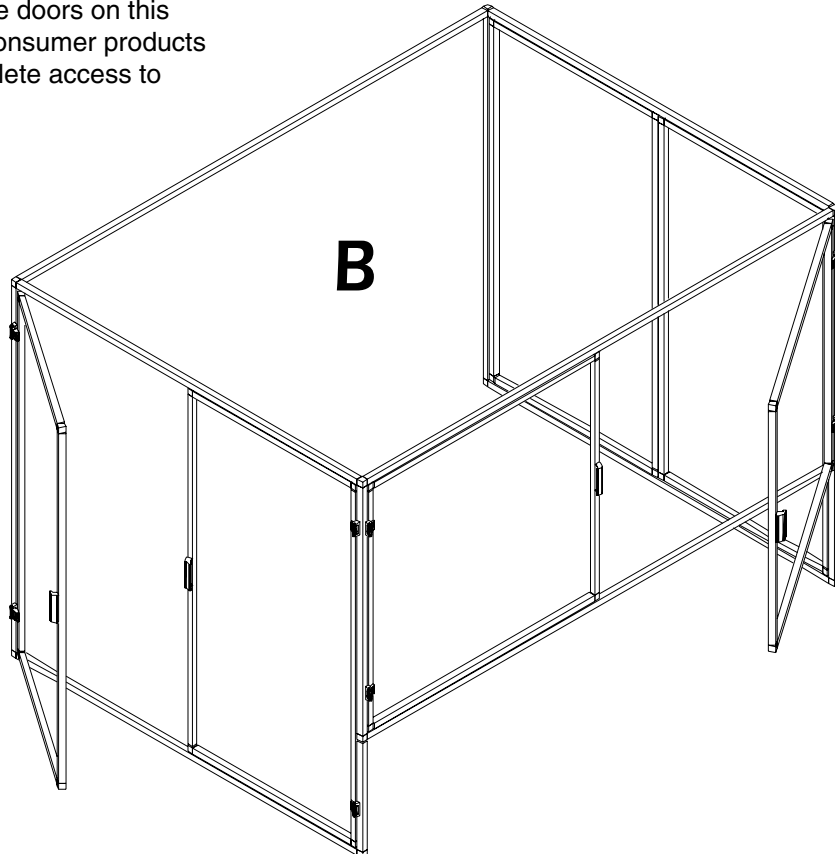

# Fixed Panel Options

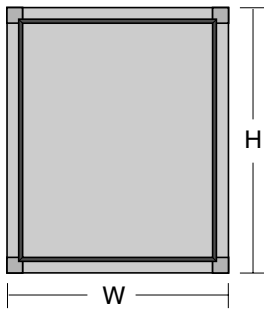

## Framed Panel with Glazing Sections

The two piece glazing section attaches to the inside of the frame and seals the panel in place, keeping out moisture and dust.

- Tube ..... SF-1000-SS (stainless steel) or SF-1000-AL (aluminum)
- Corner joint ..... SF-C2PR (plastic) or SF-C2 (die cast aluminum with insert)
- Tube length ..... H or W minus 2" for SF-C2PR  
..... H or W minus 2-1/8" for SF-C2
- Glazing section ..... SF-GZ1-14
- Glazing length ..... H or W minus 1-11/16" (miter cut)
- Plastic panel dim. .... H or W minus 2-3/8"

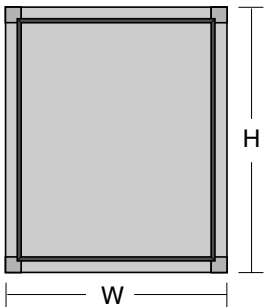
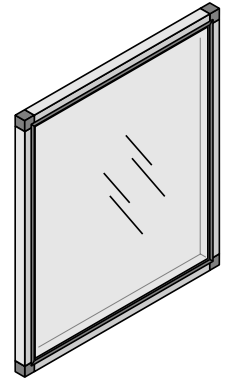
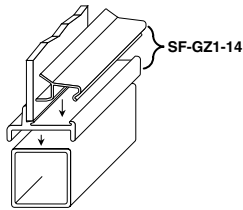

## Framed Panel with Cladding Sections

The cladding section attaches to the inside of the frame and holds the panel into place, keeping out moisture and dust.

- Tube ..... SF-1000-SS (stainless steel) or SF-1000-AL (aluminum)
- Corner joint ..... SF-C2PR (plastic) or SF-C2 (die cast aluminum with insert)
- Tube length ..... H or W minus 2" for SF-C2PR  
..... H or W minus 2-1/8" for SF-C2
- Cladding section ..... SF-CD1-14 or SF-CD1-34
- Cladding length ..... H or W minus 1-5/16" (miter cut)
- Plastic panel dim. .... H or W minus 2-3/16"

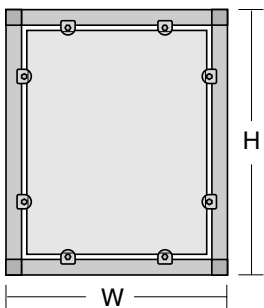
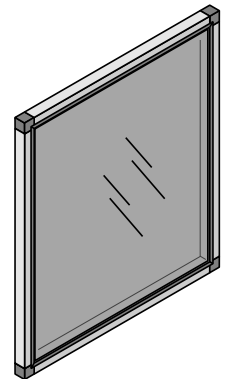
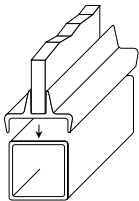

## Framed Panel with Panel Clamps

The panel clamps attach to both the tube and the panel, allowing the panel to be removed or replaced. Used where a sealed panel is not required.

- Tube ..... SF-1000-SS (stainless steel) or SF-1000-AL (aluminum)
- Corner joint ..... SF-C2PR (plastic) or SF-C2 (cast aluminum with insert)
- Tube length ..... H or W minus 2" for SF-C2PR  
..... H or W minus 2-1/8" for SF-C2
- Plastic panel dim. .... H or W minus 2-9/16" for SF-PC2-  
..... H or W minus 2 13/16" for SF-PCH-
- Panel Clamps ..... SF-PC2-14 or SF-PCH-14 for 1/4" panels  
..... SF-PC2-316 for 3/16" panels  
..... SF-PCH-38 for 3/8" panels  
..... SF-PCH-12 for 1/2" panels

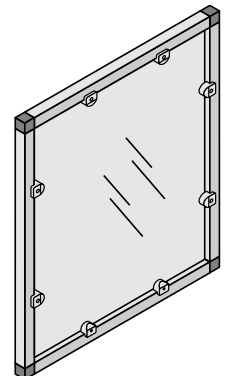
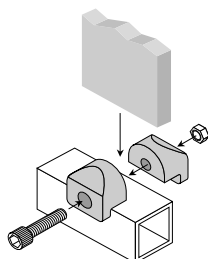

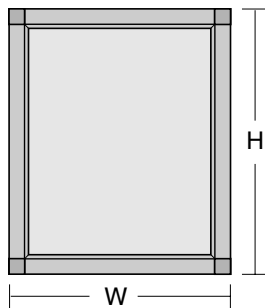

### Framed Panel with Glazing Bead

The glazing bead attaches to the aluminum glazing tube and seals the panel into place, keeping out moisture and dust.

- Tube ..... SF-1000-AZ1
- Corner joint ..... SF-C2PR (plastic) or SF-C2 (die cast aluminum with insert)
- Tube length ..... H or W minus 2" for SF-C2PR  
..... H or W minus 2-1/8" for SF-C2
- Glazing bead ..... SF-GZB-
- Glazing bead length ..... H or W minus 2"
- Plastic panel dim..... H or W minus 2-3/16"

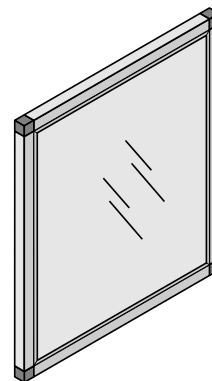
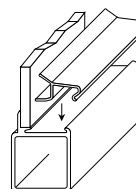

## Access Door Options

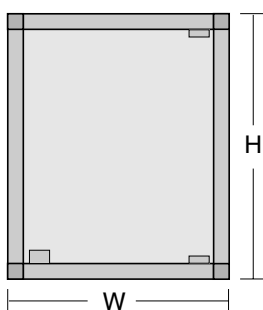

### Unframed Panel Door

Unframed panel doors are generally the simplest and least expensive style of door. The panel itself is the complete door. These doors are ideally suited for smaller openings or lighter duty applications.

#### Frame around door

- Tube ..... SF-1000-SS (stainless steel) or SF-1000-AL (aluminum)
- Corner joint ..... SF-C2PR (plastic) or SF-C2 (cast aluminum with insert)
- Tube length ..... H or W minus 2" for SF-C2PR  
..... H or W minus 2-1/8" for SF-C2
- Plastic panel dim..... H or W minus 2-3/8"

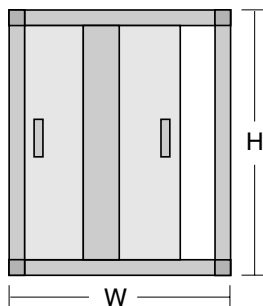
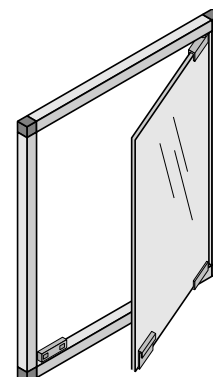

### Sliding Panel Door

Economical alternative when little or no door swing space is available. Doors are removable with sliding panel sections in place.

#### Frame around door

- Tube ..... SF-1000-SS (stainless steel) or SF-1000-AL (aluminum)
- Corner joint ..... SF-C2PR (plastic) or SF-C2 (cast aluminum with insert)
- Tube length ..... H or W minus 2" for SF-C2PR  
..... H or W minus 2-1/8" for SF-C2
- Sliding panel cladding ..... SF-SP-14-8-TOP (top)  
..... SF-SP-14-8 (bottom)
- Sliding panel cladding length..... H minus 2" (top)  
..... H minus 2" (bottom)
- Plastic panel dim..... H minus 2-9/16"  
..... (W minus 2" / 2) + 1/2"

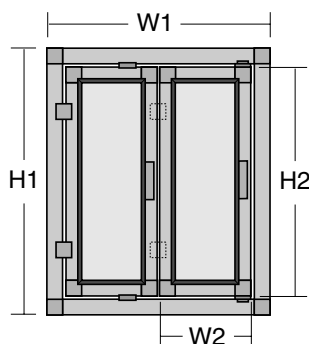
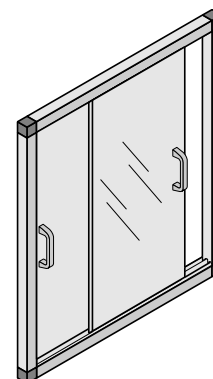

### Single Bifold Door using Glazing Sections

Most commonly used when limited door swing space is available and maximum access is needed.

- Tube ..... SF-1000-SS (stainless steel) or SF-1000-AL (aluminum)
- Corner joint ..... SF-C2PR (plastic) or SF-C2 (cast aluminum with insert)
- Tube length ..... H<sub>1</sub>, H<sub>2</sub>, W<sub>1</sub> or W<sub>2</sub> minus 2" for SF-C2PR  
..... H<sub>1</sub>, H<sub>2</sub>, W<sub>1</sub> or W<sub>2</sub> minus 2-1/8" for SF-C2
- Glazing section ..... SF-GZ1-14
- Glazing length ..... H<sub>2</sub> or W<sub>2</sub> minus 1-11/16" (miter cut)
- Plastic panel dim..... H<sub>2</sub> or W<sub>2</sub> minus 2-3/8"
- Slider ..... SF-BDS-BK
- Doorstop ..... SF-DOORSTOP-BK

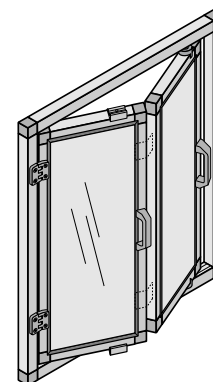

$H_2 = H_1 \text{ minus } 2-1/2"$   
 $W_2 = (W_1 \text{ minus } 2-1/2") \div 2$

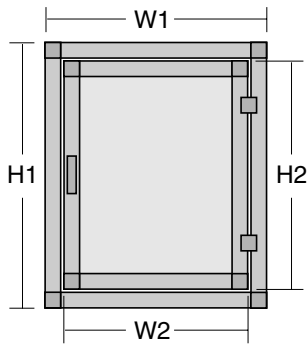
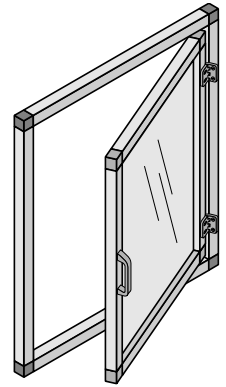

## Framed Door

Most common door, appropriate for most applications. Any of the four types of framed panels can be used for the door (see below). The hatch door is most often used on very wide doors. Configurations below result in a 1/4" gap between frame and door when using standard hinges and latches. When using pintel hinges, allow for a 1/8" gap on hinge side.

### Frame around door

- Tube ..... SF-1000-SS (stainless steel) or SF-1000-AL (aluminum)
- Corner joint ..... SF-C2PR (plastic) or SF-C2 (cast aluminum with insert)
- Tube length .....  $H_1$  or  $W_1$  minus 2" for SF-C2PR
- .....  $H_1$  or  $W_1$  minus 2-1/8" for SF-C2

### Door Panels...

$$H_2 = H_1 \text{ minus } 2\text{-}1/2", W_2 = W_1 \text{ minus } 2\text{-}1/2"$$

#### ...with Glazing Sections

- Tube ..... SF-1000-SS (stainless steel) or SF-1000-AL (aluminum)
- Corner joint ..... SF-C2PR (plastic) or SF-C2 (cast aluminum with insert)
- Tube length .....  $H_2$  or  $W_2$  minus 2" for SF-C2PR
- .....  $H_2$  or  $W_2$  minus 2-1/8" for SF-C2
- Glazing section ..... SF-GZ1-14
- Glazing length .....  $H_2$  or  $W_2$  minus 1-11/16" (miter cut)
- Plastic panel dim. ....  $H_2$  or  $W_2$  minus 2-3/8"

#### ...with Cladding Sections

- Tube ..... SF-1000-SS (stainless steel) or SF-1000-AL (aluminum)
- Corner joint ..... SF-C2PR (plastic) or SF-C2 (cast aluminum with insert)
- Tube length .....  $H_2$  or  $W_2$  minus 2" for SF-C2PR
- .....  $H_2$  or  $W_2$  minus 2-1/8" for SF-C2
- Cladding section ..... SF-CD1-14 or SF-CD1-34
- Cladding length .....  $H_2$  or  $W_2$  minus 1-5/16" (miter cut)
- Plastic panel dim. ....  $H_2$  or  $W_2$  minus 2-3/16"

#### ...with Panel Clamps

- Tube ..... SF-1000-SS (stainless steel) or SF-1000-AL (aluminum)
- Corner joint ..... SF-C2PR (plastic) or SF-C2 (cast aluminum with insert)
- Tube length .....  $H_2$  or  $W_2$  minus 2" for SF-C2PR
- .....  $H_2$  or  $W_2$  minus 2-1/8" for SF-C2
- Plastic panel dim. ....  $H_2$  or  $W_2$  minus 2-9/16" for SF-PC2-
- .....  $H_2$  or  $W_2$  minus 2 13/16" for SF-PCH-
- Panel Clamps ..... SF-PC2-14 or SF-PCH-14 for 1/4" panels
- ..... SF-PC2-316 for 3/16" panels
- ..... SF-PCH-38 for 3/8" panels
- ..... SF-PCH-12 for 1/2" panels

#### ...with Glazing Bead

- Tube ..... SF-1000-AZ1
- Corner joint ..... SF-C2PR (plastic) or SF-C2 (cast aluminum with insert)
- Tube length .....  $H_2$  or  $W_2$  minus 2" for SF-C2PR
- .....  $H_2$  or  $W_2$  minus 2-1/8" for SF-C2
- Glazing bead ..... SF-GZB-
- Glazing length .....  $H_2$  or  $W_2$  minus 2"
- Plastic panel dim. ....  $H_2$  or  $W_2$  minus 2-3/16"

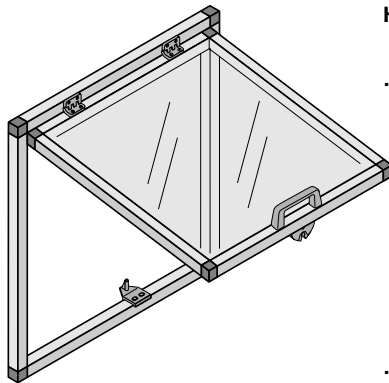

# Tubing

- 304 brushed stainless steel (-SS) or clear anodized 6063 aluminum (-AL) tubes
- 1" Sq. x .050" wall
- Aluminum tubes also available with glazing profiles
- Available in 8' and 10' lengths. Basic square tubes are also available in 20' lengths

## Square Tubing

- SF-1000-SS-08
- SF-1000-SS-10
- SF-1000-SS-20
- SF-1000-AL-08
- SF-1000-AL-10
- SF-1000-AL-20

Used for basic frame structure.

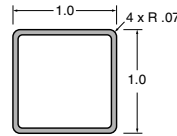
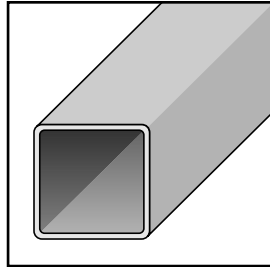

## Aluminum Glazing Tube

- SF-1000-AZ1-08
- SF-1000-AZ1-10

Retains and seals 3/16" to 1/4" thick panels. Requires SF-GZB- glazing bead.

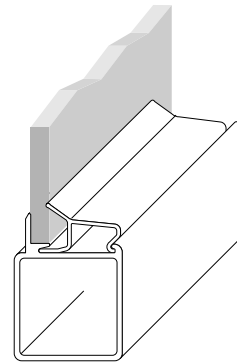
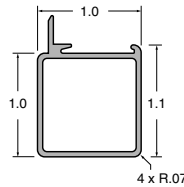
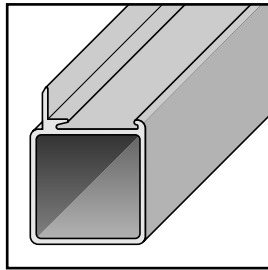

## Aluminum Glazing Tube

- SF-1000-AZ2-08
- SF-1000-AZ2-10

Retains and seals 3/16" to 1/4" thick panels on inside 90° corner. Requires SF-GZB- glazing bead.

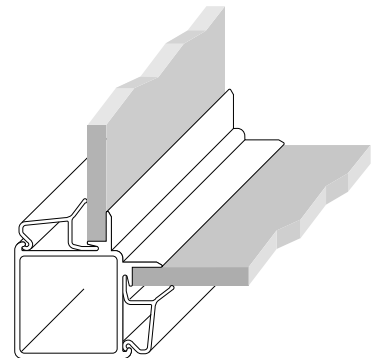
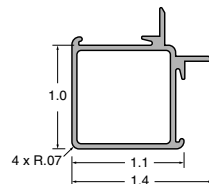
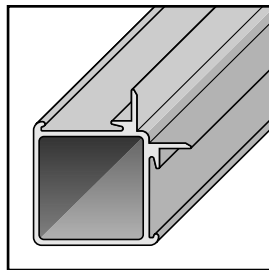



**Aluminum Glazing Tube**  
**SF-1000-AZC-08**  
**SF-1000-AZC-10**

Retains and seals adjacent 3/16" to 1/4" thick panels. Requires SF-GZB- glazing bead.

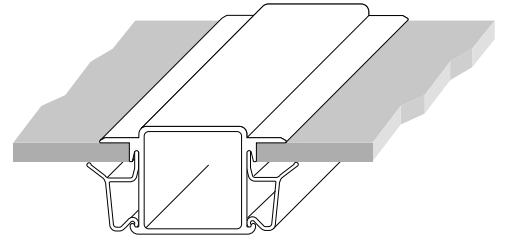
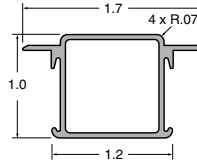
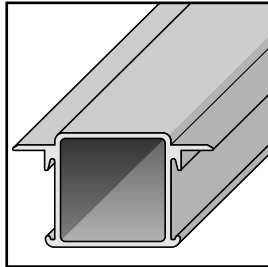

**Glazing Bead**

**SF-GZB-B-8** (black)  
 Extruded black PVC.  
 Secures 3/16" to 1/4" thick panels in tubes. Sealing lip is soft PVC which compresses against panel. Available in 8 foot nominal lengths.

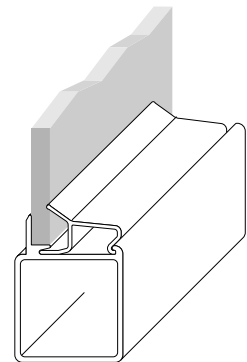
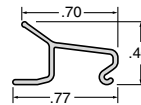
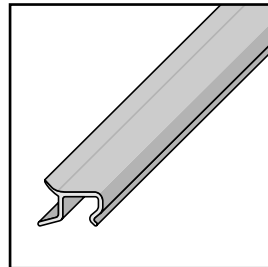

SpeedFrame

# Corner Joints: Aluminum

- Die-cast aluminum alloy joints have a black powder coated finish
- Configurations for use on SpeedFrame tubing
- All aluminum joints supplied with proper number of ABS inserts (SF-IB)
- Integrated 0.16" hole for drive screw (pg. 47) or hinge pin

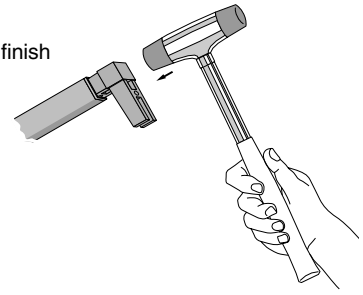

## 2-Way Corner Joint SF-C2

Connects 2 tubes at a corner.

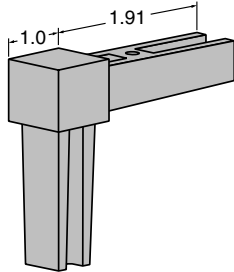

## 2-Way Rounded Corner Joint SF-CR2

Connects 2 tubes at a corner.

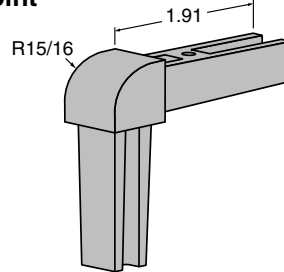

## 3-Way Tee Joint SF-T3

Connects 3 tubes at a tee.

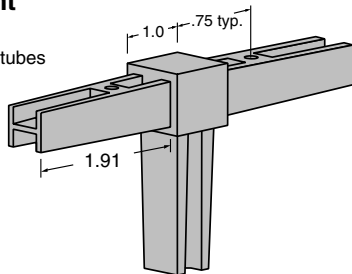

## 3-Way Corner Joint SF-C3

Connects 3 tubes at a corner.

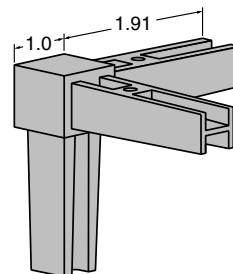

## 3-Way Rounded Corner Joint SF-CR3

Connects 3 tubes at a corner.

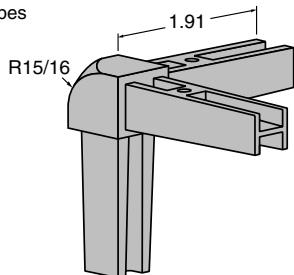

## 4-Way Corner Joint SF-CT4

Connects 4 tubes at a corner.

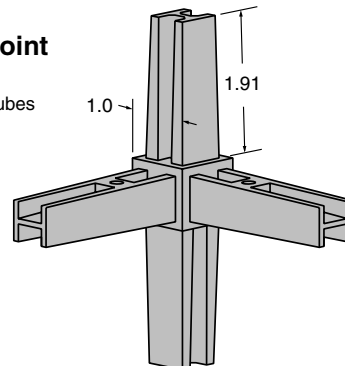

## Tubing Inserts

### SF-IB (black)

Rigid black ABS inserts are used for permanent structures and are supplied with each joint.

### SF-IW (white)

White polyethylene inserts are used for structures requiring frequent disassembly and can be ordered separately.

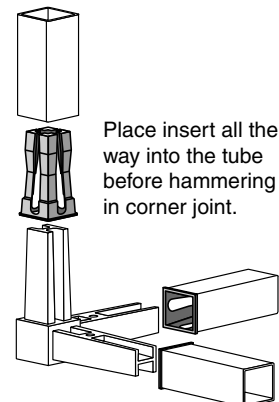
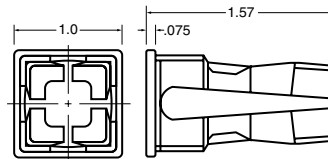
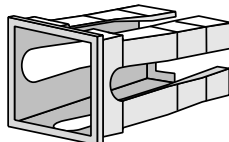
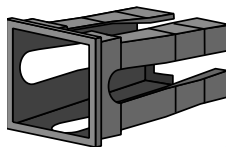

Place insert all the way into the tube before hammering in corner joint.

# Plastic Corner Joints: Steel Reinforced

- Glass filled polyamide construction
- Three configurations for use on SpeedFrame tubing
- Joints connect into tubing without inserts
- For heavy duty applications, steel reinforced joints are 50% stronger

**2-Way Plastic Corner Joint**  
**SF-C2PR-BK**  
Connects 2 tubes at a corner.

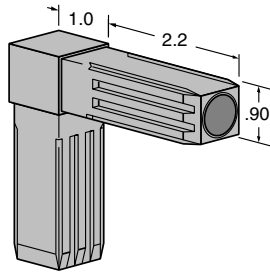

Molded in steel reinforcement tube

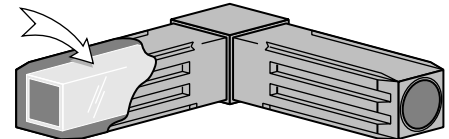

**3-Way Plastic Tee Joint**  
**SF-T3PR-BK**  
Connects 3 tubes at a tee.

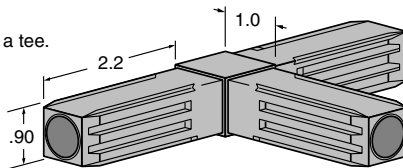

**3-Way Plastic Corner Joint**  
**SF-C3PR-BK**  
Connects 3 tubes at a corner.

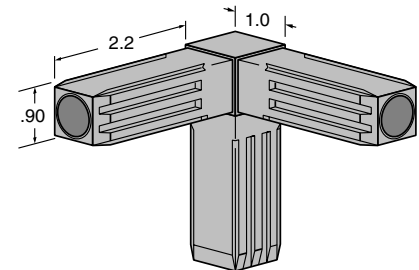

**Internal Connector**  
**SF-C1P**  
Connects two tubes at 90° without using a 90° Corner Joint. Used to make 4, 5, and 6 way connections. Available in gray polyamide.

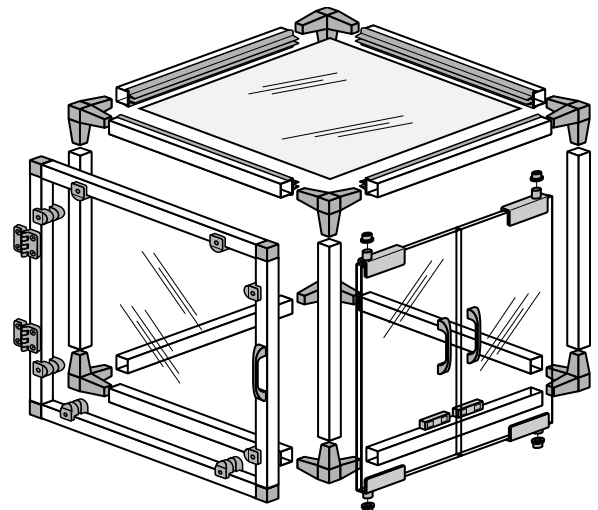
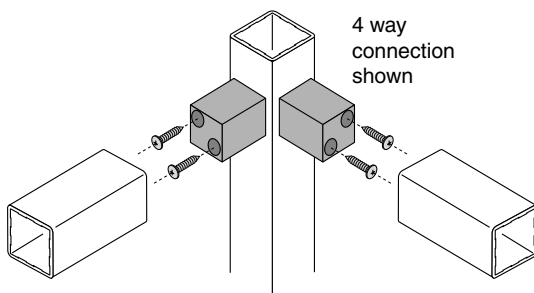
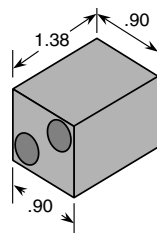

# Cladding Sections

- Durable, black PVC
- Snaps tightly onto 1" tube
- Fins conceal edges of panels
- Attached before frame assembly

## Single Cladding Section SF-CD1-14-8

Holds single panel of plastic, wood or laminate. Cladding fin accepts 1/4" panel. Eight foot nominal lengths.

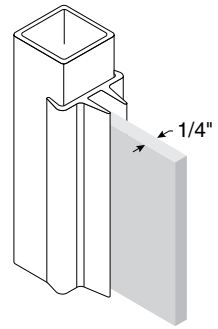
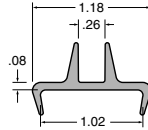
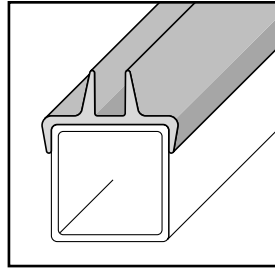

## 2-Way Cladding Section SF-CD2-14-8

Holds two panels of plastic, wood or laminate in a corner. Cladding fin accepts 1/4" panels. Eight foot nominal lengths.

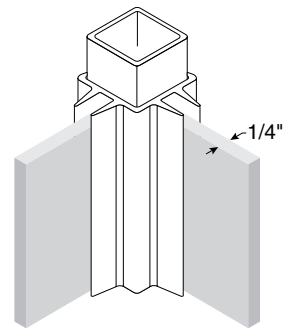
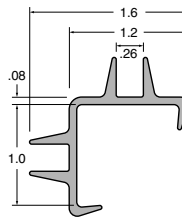
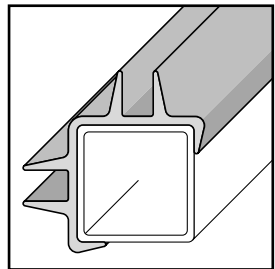

## Top Sliding Panel Cladding Section SF-SP-14-8-TOP

Used to make sliding doors with panels up to 1/4" thick. Deeper channel allows for panel removal.

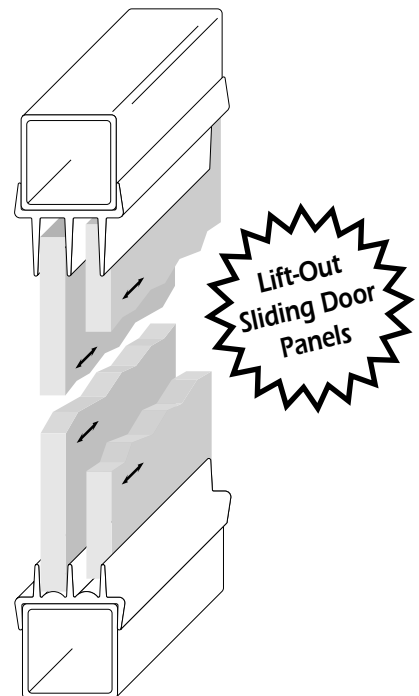
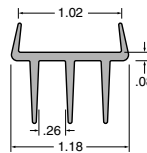
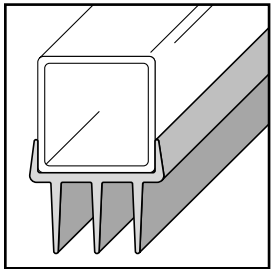

## Bottom Sliding Panel Cladding Section SF-SP-14-8

Used to make sliding doors with panels up to 1/4" thick.

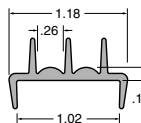
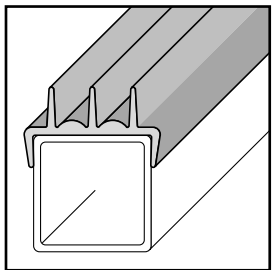

# Glazing Sections

- Durable, black PVC
- Snaps tightly onto 1" tube
- Designed for panel removal
- May be attached after frame assembly

## Single Glazing Section

### SF-GZ1-14-8

Holds 3/16" to 1/4" thick glass or plastic panels. Each section consists of two parts: the cladding base strip and snap-in glazing bead. Sealing lip is soft PVC which compresses against panel. Eight foot nominal lengths.

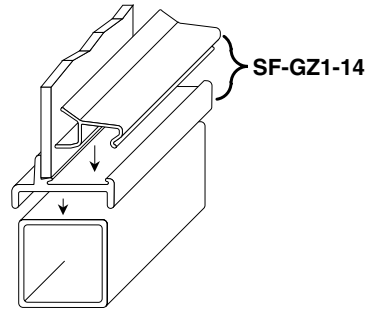
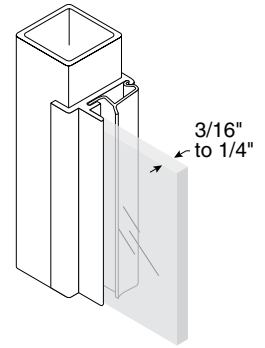
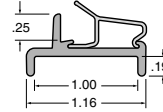
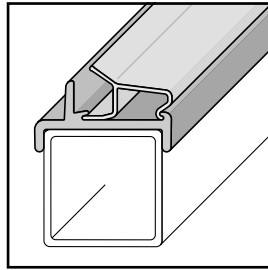

## 2-Way Glazing Section

### SF-GZ2-14-8

Holds 3/16" to 1/4" thick glass or plastic panels in a corner. Each section consists of two parts: the cladding base strip and snap-in glazing bead. Sealing lip is soft PVC which compresses against panel. Eight foot nominal lengths.

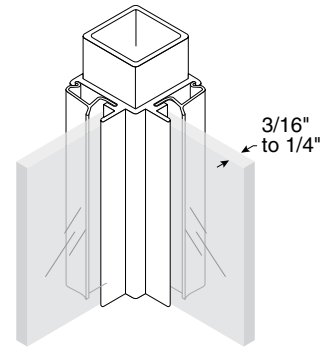
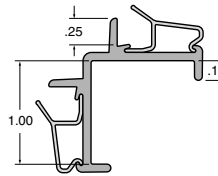
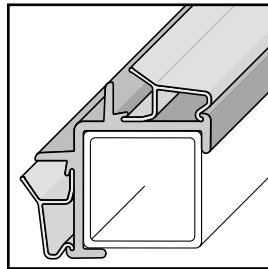

# Panel Clamps

**SF-PC3-116** (black)

**SF-PC3-116-GR** (gray)

Black or gray acetal clamps with stainless steel screw and nickel plated brass nut. Designed to hold 14 ga. to 16 ga. panels in 1" square SpeedFrame tubing or FlexTech Series 25 tubing. Recommended maximum panel sizes: vertical panels: 24" x 36" horizontal panels: 24" x 24"

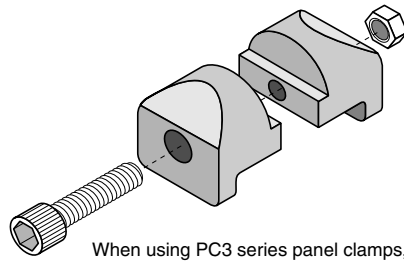

**NEW**

When using PC3 series panel clamps, panel height or width is tube to tube inside dimension minus 11/16".

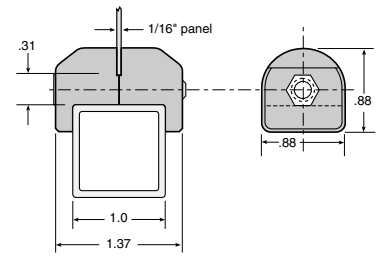

**SF-PC3-14** (black)

**SF-PC3-14-GR** (gray)

Black or gray acetal clamps with stainless steel screw and nickel plated brass nut. Designed to hold 1/4" panels in 1" square SpeedFrame tubing or FlexTech Series 25 tubing. Recommended maximum panel sizes: vertical panels: 24" x 36" horizontal panels: 24" x 24"

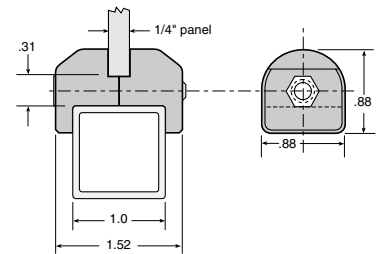
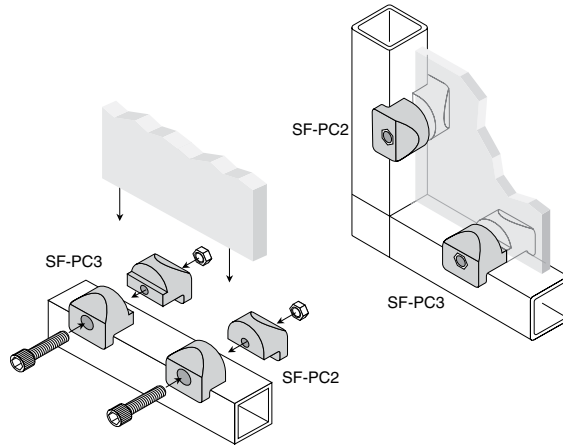

**Panel Clamp**

**SF-PC2-316** (black)

**SF-PC2-316-GR** (gray)

Black or gray acetal clamps with stainless steel screw and nickel plated brass nut. Designed to hold 3/16" panels in 1" square SpeedFrame tubing or FlexTech Series 25 tubing. Recommended maximum panel sizes: vertical panels: 24" x 36" horizontal panels: 24" x 24"

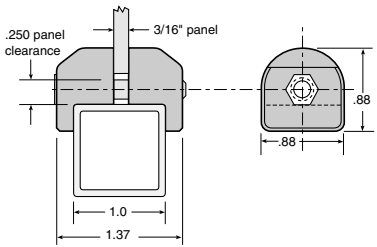
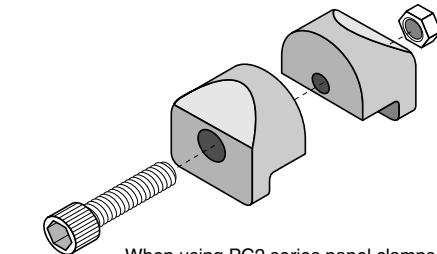

**SF-PC2-14** (black)

**SF-PC2-14-GR** (gray)

Black or gray acetal clamps with stainless steel screw and nickel plated brass nut. Designed to hold 1/4" panels in 1" square SpeedFrame tubing or FlexTech Series 25 tubing. Recommended maximum panel sizes: vertical panels: 24" x 36" horizontal panels: 24" x 24"

When using PC2 series panel clamps, panel height or width is tube to tube inside dimension minus 9/16".

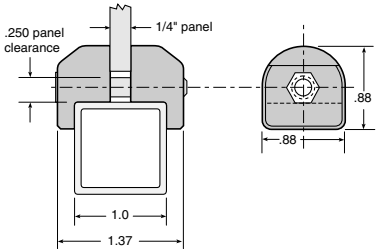

**Heavy Duty Panel Clamp**

**SF-PCH-14** (black)

**SF-PCH-14-GR** (gray)

Black or gray acetal clamps with stainless steel fasteners and nickel plated brass nut. Designed to hold 1/4" panels in 1" square SpeedFrame tubing. Recommended maximum panel sizes: vertical panels: 36" x 96" horizontal panels: 24" x 72"

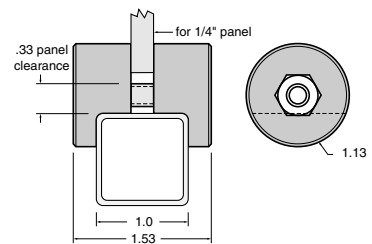
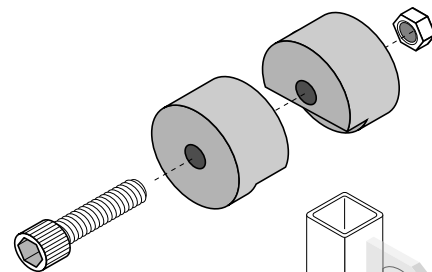

**SF-PCH-38** (black)

**SF-PCH-38-GR** (gray)

Black or gray acetal clamps with stainless steel fasteners and nickel plated brass nut. Designed to hold 3/8" panels in 1" square SpeedFrame tubing. Recommended maximum panel sizes: vertical panels: 36" x 96" horizontal panels: 24" x 72"

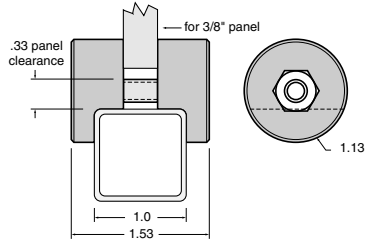
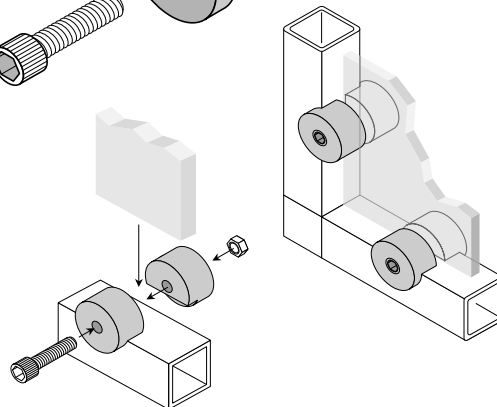

**SF-PCH-12** (black)

**SF-PCH-12-GR** (gray)

Black or gray acetal clamps with stainless steel fasteners and nickel plated brass nut. Designed to hold 1/2" panels in 1" square SpeedFrame tubing. Recommended maximum panel sizes: vertical panels: 36" x 96" horizontal panels: 24" x 72"

When using PCH series panel clamps, panel height or width is tube to tube inside dimension minus 3/4".

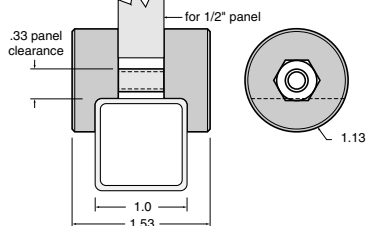

# Handles

## Standard Duty Handle

**VG-631-14** (black)  
**VG-631-14-GR** (gray)  
 Reinforced black or gray polyamide with brass insert.

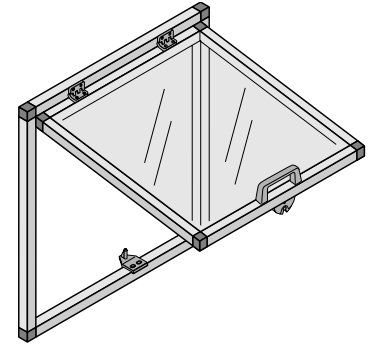
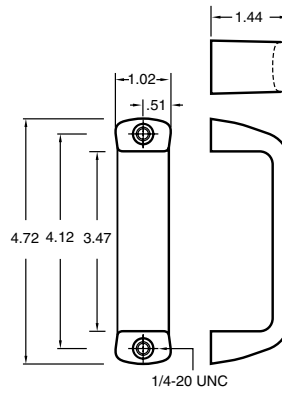
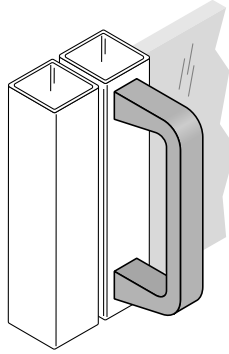
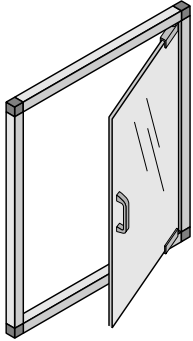

## Safety Handle

**VG-630-BK**  
 Reinforced black polyamide with 304 stainless steel screws and polyamide caps included. Closed design allows easy opening without pinched fingers and scraped knuckles when handles are mounted side by side on adjacent doors. Fasteners and tube hole caps included.

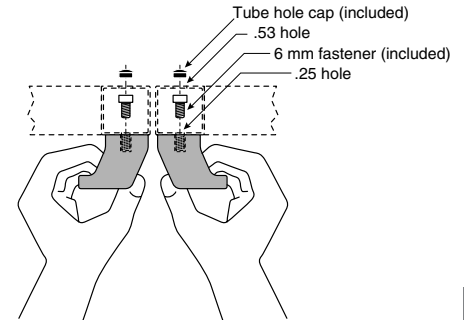
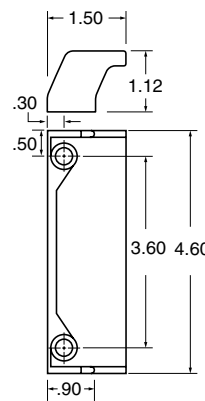
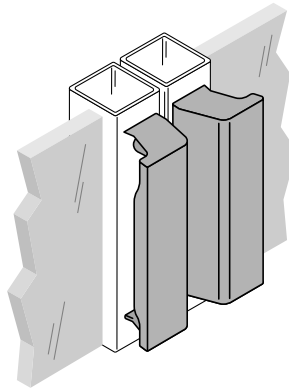

For additional handles, see page 17

# Doorstop

## Doorstop

**SF-DOORSTOP-BK**  
 Reinforced black polyamide doorstop positions closed door flush with frame. Designed for 1/4" gap between door and frame. Fastener included.

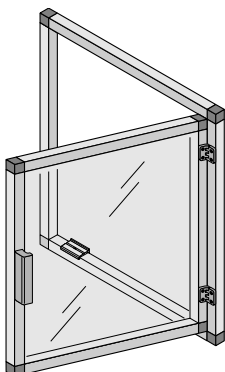
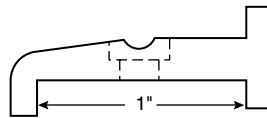
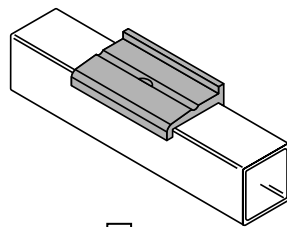

# Bifold Door Slider

## Door Slider for Bifold Doors

**SF-BDS-BK**  
 Black acetal Bifold Door Slider is used on the top and bottom sliding ends of bifold doors. The pin is inserted into a .396" dia. hole drilled into the middle of a corner joint.

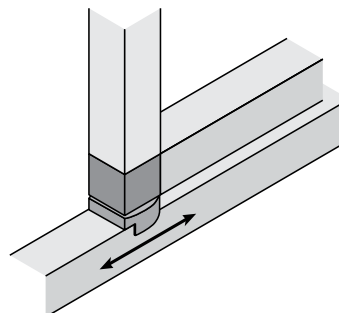
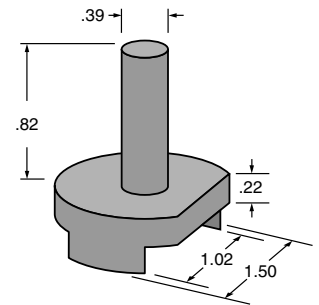

# Latches

## Spring Latch

### SF-SLATCH-BK

Reinforced black polyamide latch for framed doors. Requires handle on door. Mounting hardware included. Designed for 1/4" gap between door and frame.

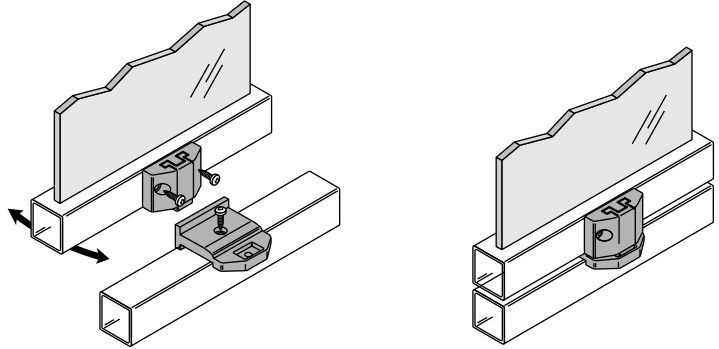
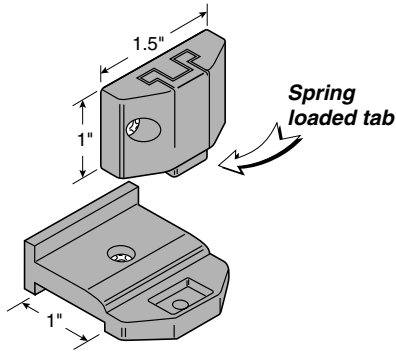

## Finger Lift Latch

### SF-FLATCH-BK

Reinforced black polyamide latch for framed doors. No door handle required. Mounting hardware included. Designed for 1/4" gap between door and frame.

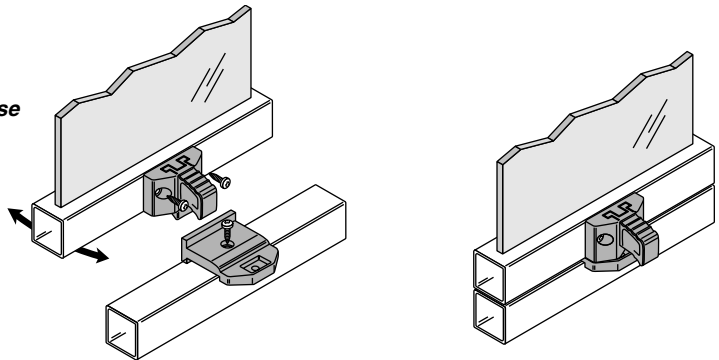
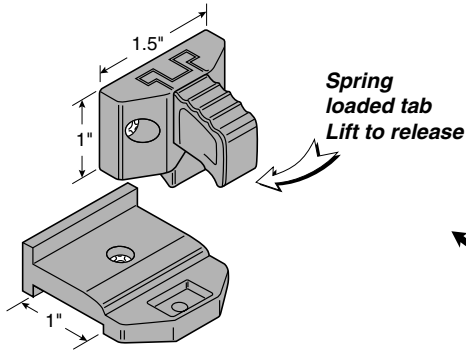

## V Latch

### SF-VLATCH-BK

Reinforced black polyamide latch for framed doors. Requires handle on door. Mounting hardware included. Designed for 1/4" gap between door and frame.

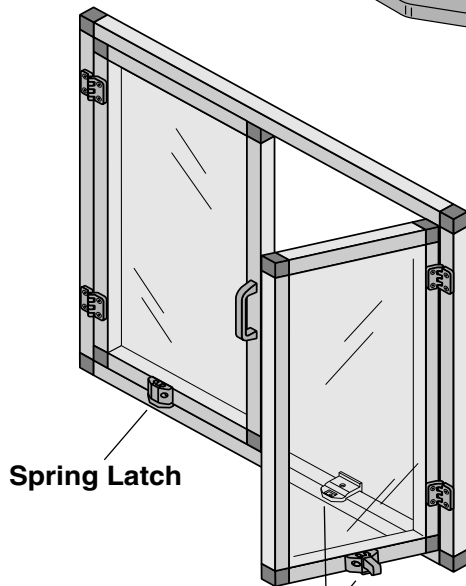
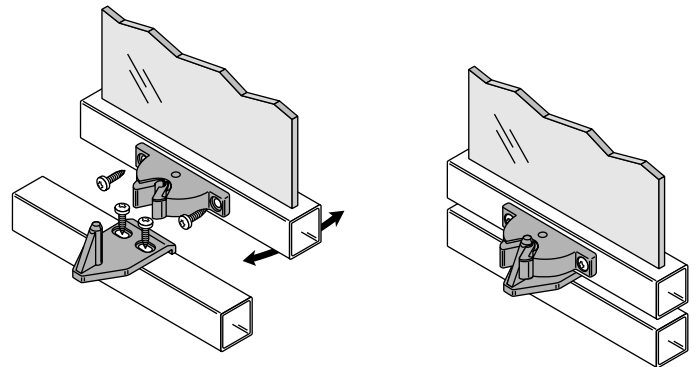
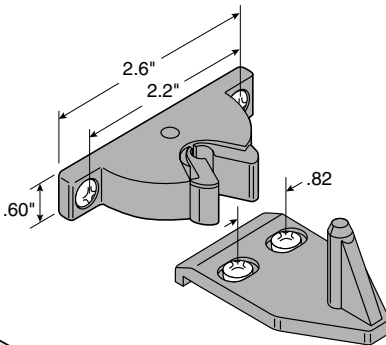

Spring Latch

Finger Lift Latch

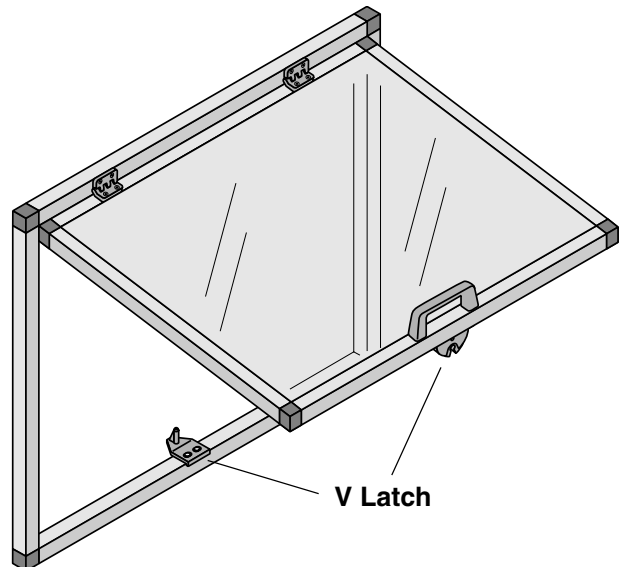

V Latch



# Latch Kits

## Latch Kit SF-LK-B

Kit includes a zinc plated steel handle/pawl assembly, a polymer keeper and 2 steel doorstops. Mounting hardware included. Designed for 1/4" gap between door and frame.

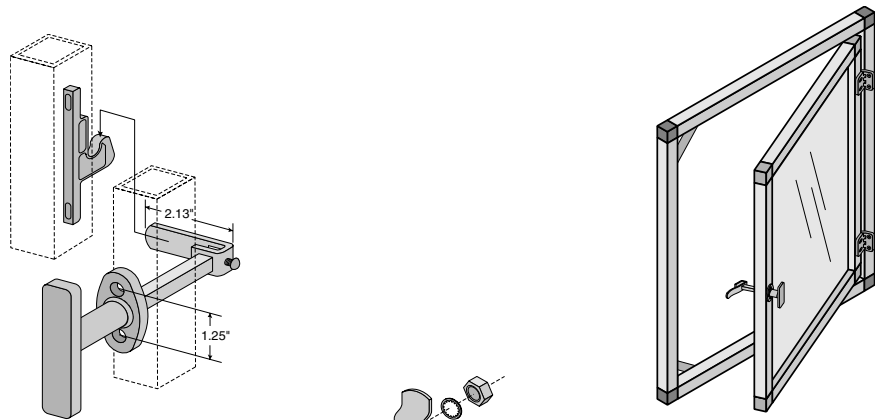

## Latch Kit SF-LK-C

Kit includes a black zinc plated steel handle/pawl assembly, and 2 steel doorstops. Designed for 1/4" gap between door and frame.

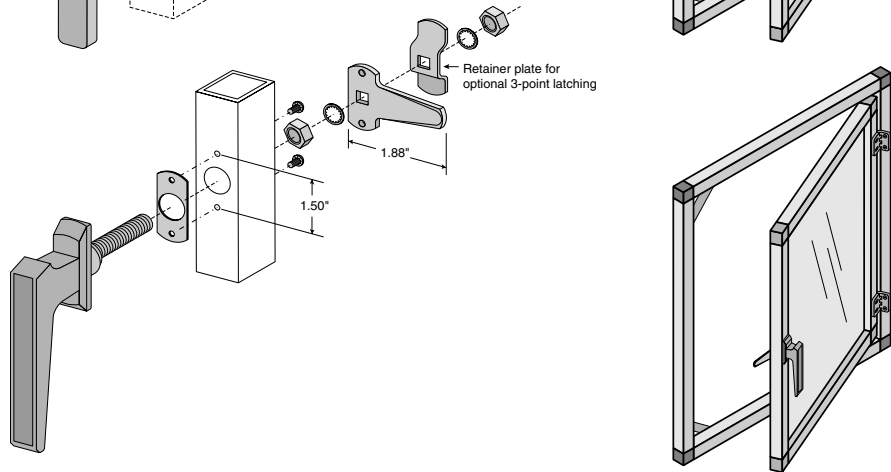

# Shelf Supports

## Shelf Support

- SF-SR-1
- SF-SR-2
- SF-SR-3
- SF-SR-4

Black enameled steel support hooks firmly around horizontal tubes to support rigid 1/4", 1/2", 3/4" or 1" shelf panels. Maximum static load is 200 lbs. per 4 supports.

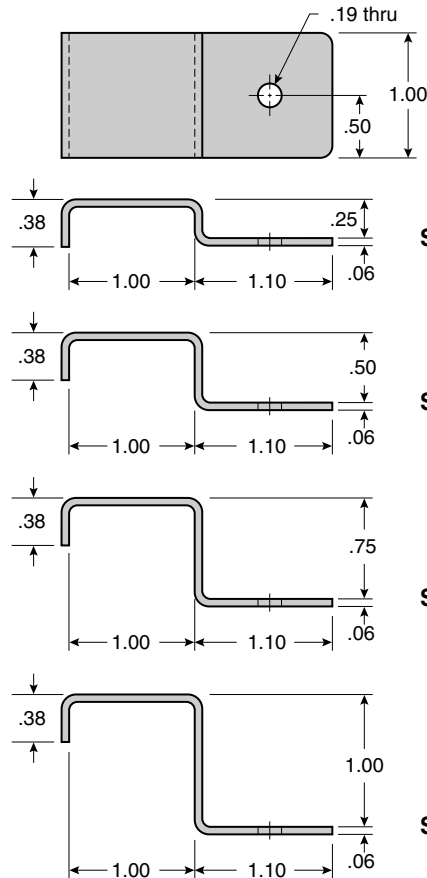

SF-SR-1

SF-SR-2

SF-SR-3

SF-SR-4

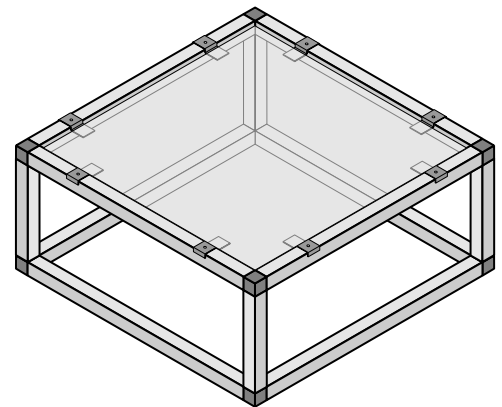

# Hinges

**Pintel Hinges:**  
**Free Swinging,**  
**Size C and D**  
**SF-HNG-CLFS**  
**SF-HNG-CRFS**  
**SF-HNG-DLFS**  
**SF-HNG-DRFS**

Made of glass reinforced,  
 black polyamide.

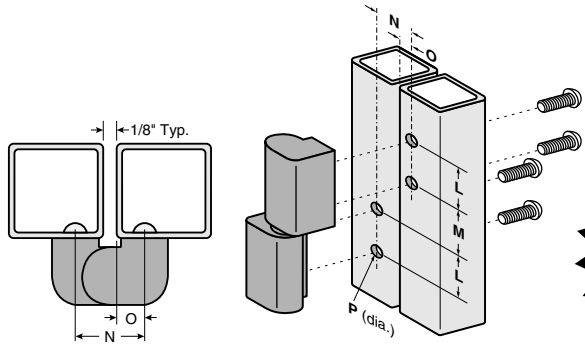
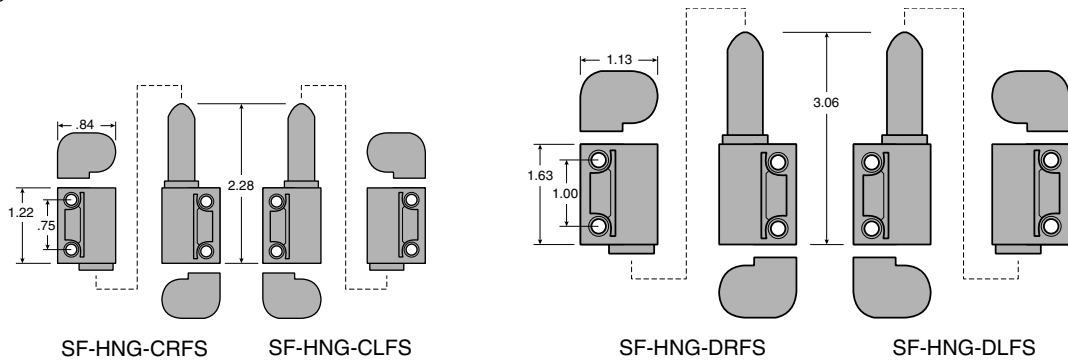

	Installation Dimensions (inches)					Screw thread size
	L	M	N	O	P dia.	
<b>SF-HNG-C</b>	.75	.56	.75	.317	.196	10-24
<b>SF-HNG-D</b>	1.00	.75	1.00	.437	.265	1/4-20

Screws not included. Hinge designed for 1/8" gap between door and frame.

Free swinging, non-lift off doors with  
 size C or D hinges requires:

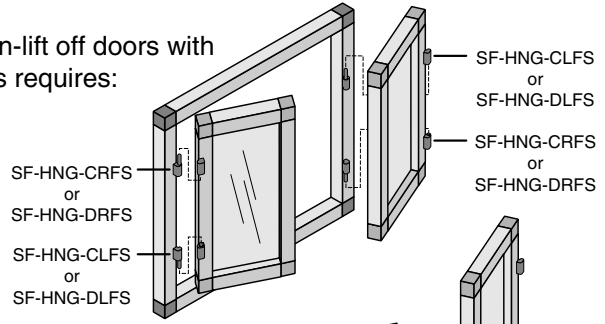

Free swinging, lift-off  
 doors with size C or D  
 hinges requires:

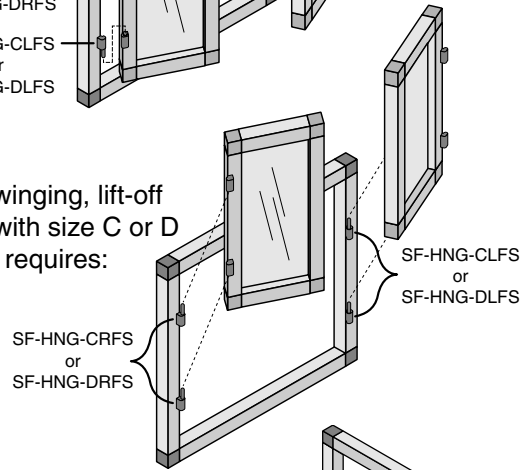

## Standard Hinge VG-635-BK

Made of reinforced, black  
 polyamide. Use for swinging  
 doors and panels. Designed  
 for 1/4" gap between door and  
 frame. Fasteners not included.  
 Requires #10 screw.

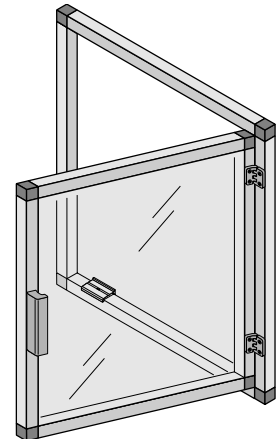
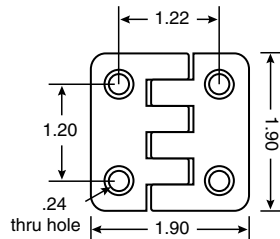
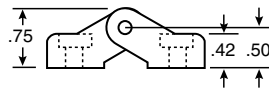
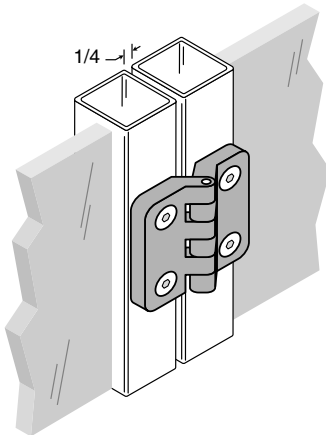
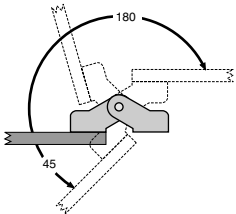

## Frameless Door Hardware Kit

**SF-HK-BB** (black)

**SF-HK-BC** (chrome)

Hardware kit provides all the components needed for mounting one  
 frameless door. Each kit includes: 2 hinges with bushings and shim  
 plates, 1 handle with adhesive gasket and 1 magnetic catch. Use a  
 1/4" thick panel cut to the recommended clearance dimensions.

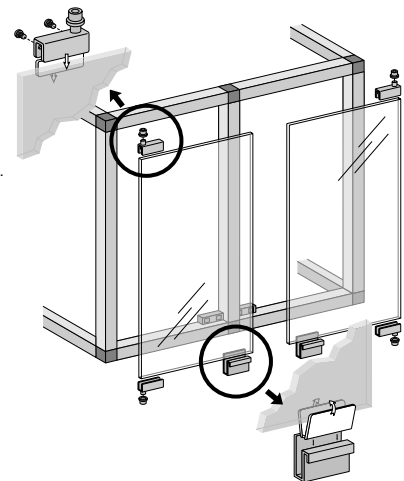
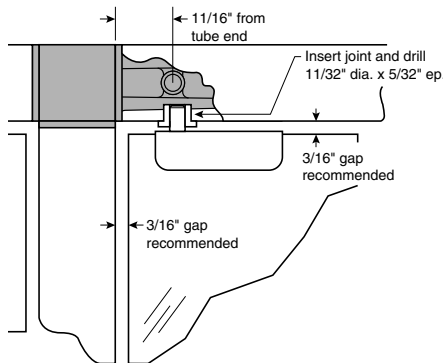
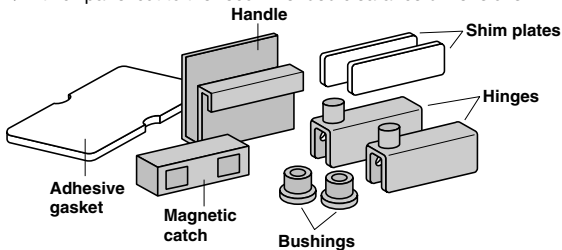

# Tube Ends and Anchor Plate

## Metal Tube End SF-ECM

Zinc plated steel cap or foot for load bearing structures. Maximum static load is 500 lbs.

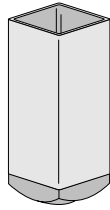
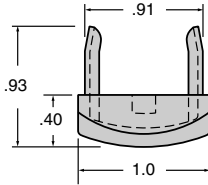

## Plastic Tube End SF-ECP

Black polyethylene cap or foot for lightweight structures. Maximum static load is 100 lbs.

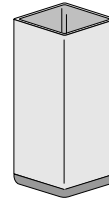
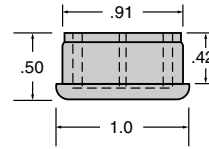

## Threaded Tube End SF-ECT-38

Plated steel tube end with 3/8-16" internal threads. Maximum static load is 100 lbs.

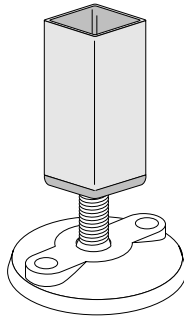
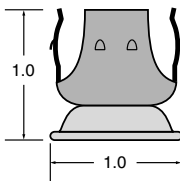

## Anchor Plate SF-AP-2

Black powder coated steel plate that connects to SpeedFrame tubing. When assembled to a tube, they provide a simple, rigid method for attaching frame structures to horizontal and vertical surfaces. Fasteners not included.

**NEW**

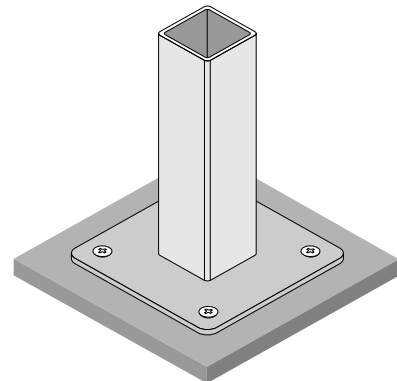
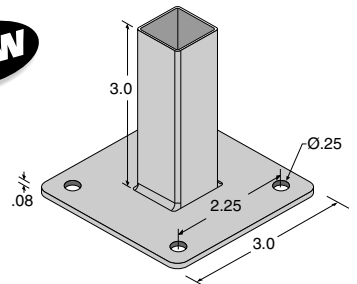

## Drive Screw SF-DS

Zinc plated screw makes joint connections resistant to pull out due to excessive loads or vibration. Screw is driven into a .16" dia. drilled hole with a hammer.

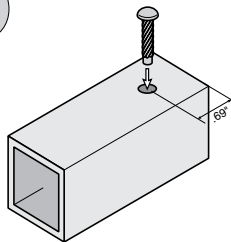

## Drill Jig SF-DJ

Locates drill holes for hinge pins through the tube and into the joint in one easy operation, eliminating the need to pre-punch or mark the tube.

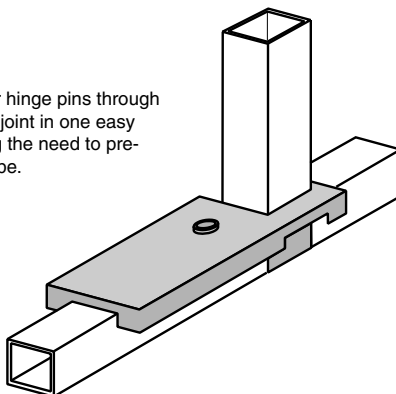

# Index

11044	24	FT-30-PA-J2S-GR	12	Internal Corner Adapter	14	SF-PC3-14-GR	42
11045	24	FT-30-PA-J3S-GR	12	Internal Hinge Corner Joints	13	SF-PCH-12	42
14037	24	FT-30-PA-JT3-GR	11	Latches	19, 44, 45	SF-PCH-12-GR	42
180° Panel Glazing Tube	8	FT-30-PA-MT	13	Mandrel for M6 Rivet Nut	24	SF-PCH-14	42
2-Way Corner Joint	38, 39	FT-30-PA-PLG	13	Miterless Corner Joint	13	SF-PCH-14-GR	42
3 Way Corner Joint --	11, 12, 38, 39	FT-30-PLT	23	Miterless Tee Connectors	13	SF-PCH-38	42
3-Way Tee Joint	38, 39	FT-30-SUP-01	23	Mounting Block Kit	16	SF-PCH-38-GR	42
45° Corner Joint	12	FT-30-SUP-02	23	Panel Clamps	16, 42	SF-SLATCH-BK	44
45° Side Adapter	14	FT-30T-10-AN	8	Panel Cleaning Solution	24	SF-SP-14-8	40
4-Way Corner Joint	38	FT-30T-10-LX	8	Panel Glazing Adapter	9	SF-SP-14-8-TOP	40
90° Corner Joint	11, 12	FT-30T-FDS-10-AN	10	Panel Glazing Bead	15	SF-SR-1	45
90° Panel Glazing Tube	8	FT-30T-FDS-10-LX	10	Panel Glazing Tube	8	SF-SR-2	45
90° Rounded Corner Joint	12	FT-30T-PF-10-AN	8	Panel Mounting Tube	10	SF-SR-3	45
Adapters	14	FT-30T-PF-10-LX	8	Panel Seal Adapter	9	SF-SR-4	45
Aluminum Glazing Tube	36, 37	FT-30T-PF-180-10-AN	8	Panel Seal Tube	8	SF-T3	38
Angle Braces	23	FT-30T-PF-180-10-LX	8	Panel Seals	15	SF-T3PR-BK	39
Assembly Accessories	24	FT-30T-PF-90-10-AN	8	Pinel Hinges	46	SF-VLATCH-BK	44
Bifold Door Slider	43	FT-30T-PM-10-AN	10	Pop Rivet Installation Tool	24	Shelf Supports	45
Bifold Track Adapter	9	FT-30T-PM-10-LX	10	Pop Rivets	24	Shoulder Bolts	24
Bifold Track Tube	9	FT-30T-PS-10-AN	8	Quick Pick Guard Selector	25	Sliding Panel Tube	10
Bumper Caps	24	FT-30T-PS-10-LX	8	Rivet Nut Installation Tool	24	Square Aluminum Tubes	8
Cladding Sections	40	FT-30T-PT-10-AN	9	Rivet Nuts	24	Square Stainless Tubes	36
Corner Joints: Aluminum	38	FT-30T-PT-10-LX	9	Rounded Miterless Corner Joint	13	Steel Reinforced Corner Joints--	12
Door Closures	18, 19	FT-END-01-BK	24	Safety Handle	43	Tee Joint	11
Door Magnet Kits	18	FT-END-02-BK	24	Seal Bead	15	Threaded Tube Ends	24
Door Stop	24, 43	FT-FAST-01	24	SF-1000-AL-08	36	Tube Caps	24
FlexTech Accessories	24	FT-FAST-02	24	SF-1000-AL-10	36	Tube Ends	47
Framed Door Seal Tube	10	FT-FDLAT-01	19	SF-1000-AL-20	36	Tubing Inserts	38
FT-25-ADP-01-GR	14	FT-FDLAT-02	19	SF-1000-AZ1-08	36	VG-1001	24
FT-25-ADP-R1-GR	14	FT-FDS-GZ-10-LX	15	SF-1000-AZ1-10	36	VG-1002	24
FT-25-ADP-R2-GR	14	FT-FDS-GZ-30-LX	15	SF-1000-AZ2-08	36	VG-1003	24
FT-25-BRC-03	23	FT-GS-1220	22	SF-1000-AZ2-10	36	VG-1004	24
FT-25-BRC-04	23	FT-GS-1240	22	SF-1000-AZC-08	37	VG-630-BK	43
FT-25-CAP-GR	24	FT-GS-2020	22	SF-1000-AZC-10	37	VG-631-14	43
FT-25C-PF-10-AN	9	FT-GS-2040	22	SF-1000-SS-08	36	VG-631-14-GR	43
FT-25C-PF-10-LX	9	FT-GS-2080	22	SF-1000-SS-10	36	VG-635-BK	46
FT-25C-PS-10-AN	9	FT-GSMB-1	22	SF-1000-SS-20	36	Wire Mesh Panels	14
FT-25C-PS-10-LX	9	FT-GSMB-6	22	SF-AP	47		
FT-25-PA-J2-GR	11	FT-HDL-1-CAP-BK	17	SF-BDS-BK	43		
FT-25-PA-J2M-GR	13	FT-HDL-1-CAP-OR	17	SF-C1P	39		
FT-25-PA-J2MR-GR	13	FT-HDL-1C-GR	17	SF-C2	38		
FT-25-PA-J2RS-45-GR	12	FT-HDL-1-GR	17	SF-C2PR-B	39		
FT-25-PA-J2RS-GR	12	FT-HDS-01-GR	24	SF-C3	38		
FT-25-PA-J2S-GR	12	FT-HNG-01-AL-AN	20	SF-C3PR-BK	39		
FT-25-PA-J3-GR	11	FT-HNG-01-AL-LX	20	SF-CD1-14-8	40		
FT-25-PA-JLH-GR	13	FT-HNG-02-SS	21	SF-CD2-14-8	40		
FT-25-PA-JMLH-GR	13	FT-HNG-21-AL-GR	20	SF-CR2	38		
FT-25-PA-JMRH-GR	13	FT-HNG-22-AL-AN	20	SF-CR3	38		
FT-25-PA-JRH-GR	13	FT-HNG-22-AL-LX	20	SF-CT4	38		
FT-25-PA-JT3-GR	11	FT-LAT-01	19	SF-DJ	47		
FT-25-PA-MT	13	FT-MAG-21-GR	18	SF-DOORSTOP-BK	43		
FT-25-PA-PLG	13	FT-MAG-22-GR	18	SF-DS	47		
FT-25-PLT	23	FT-MAG-31-GR	18	SF-ECM	47		
FT-25T-10-AN	8	FT-MAG-32	18	SF-ECP	47		
FT-25T-10-LX	8	FT-MESH	14	SF-ECT-38	47		
FT-25T-PF-10-AN	8	FT-PCP-GR	24	SF-FLATCH-BK	44		
FT-25T-PF-10-LX	8	FT-PF-GZ1-10-GR	15	SF-GZ1-14-8	41		
FT-25T-PF-180-10-AN	8	FT-PF-GZ1-30-GR	15	SF-GZ2-14-8	41		
FT-25T-PF-180-10-LX	8	FT-PF-GZ2-10-GR	15	SF-GZB-B-8	37		
FT-25T-PS-10-AN	8	FT-PF-GZ2-30-GR	15	SF-HK-BB	46		
FT-25T-PS-10-LX	8	FT-PIN1-DL	21	SF-HK-BC	46		
FT-25T-SPB-10-AN	10	FT-PIN2	21	SF-HNG-CLFS	46		
FT-25T-SPB-10-LX	10	FT-PMB-01-CLR	16	SF-HNG-CRFS	46		
FT-25T-SPT-10-AN	10	FT-PMB-01-GR	16	SF-HNG-DLFS	46		
FT-25T-SPT-10-LX	10	FT-PMC1-GR	16	SF-HNG-DRFS	46		
FT-30-ADP-01-GR	14	FT-PMC2-GR	16	SF-IB	38		
FT-30-CAP-GR	24	FT-PS-DS1-10-GR	15	SF-IW	38		
FT-30C-PF-10-AN	9	FT-PS-DS1-30-GR	15	SF-LK-B	45		
FT-30C-PF-10-LX	9	Gas Springs	22	SF-LK-C	45		
FT-30C-PS-10-AN	9	Glazing Bead	37	SF-PC2-14	42		
FT-30C-PS-10-LX	9	Glazing Sections	41	SF-PC2-14-GR	42		
FT-30C-PT-10-AN	9	Handles	17, 43	SF-PC2-316	42		
FT-30C-PT-10-LX	9	Hardware Mounting Details	26	SF-PC2-316-GR	42		
FT-30-PA-J2-GR	11	Hardware Table	29	SF-PC3-116	42		
FT-30-PA-J2RS-45-GR	12	Hinges	20, 21, 46	SF-PC3-116-GR	42		
FT-30-PA-J2RS-GR	12	Internal Connectors	13, 39	SF-PC3-14	42		