

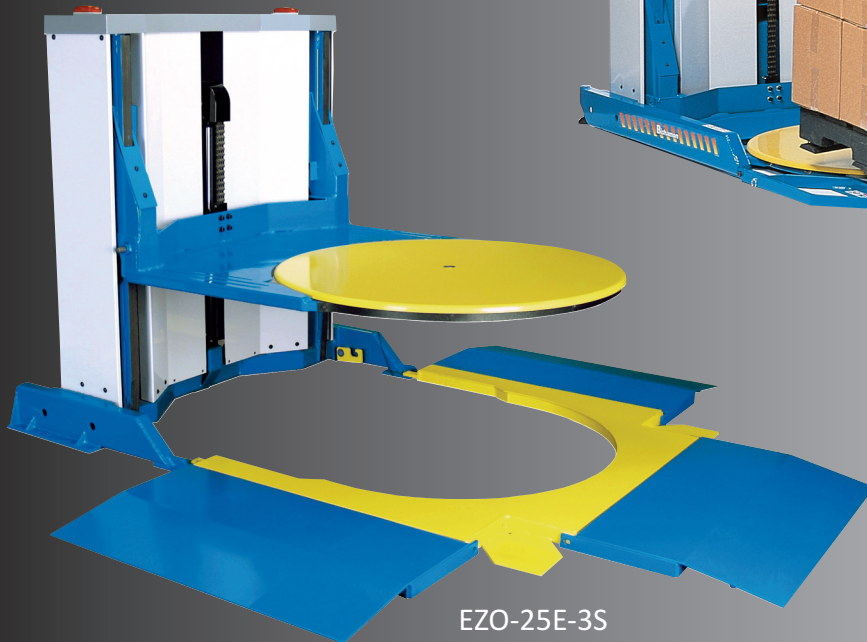

EZ-Off Lifter®

*The Bishamon EZ-OFF Lifter
Provides The Convenience
of Pallet Truck Accessibility
With a Rotating Platform!*

EZO-25E



EZO-25E-3S



Learn More at: bishamon.com

Experience Industry's
"Best Engineered"
Ergonomic Equipment

Working Harder To Make Your Job Easier

EZ-OFF LIFTER®

Model	Operation	Voltage	Capacity (lbs)	Lowered Height (in)	Raised Height (in)	Max. Pallet Size (in)	Ramp Positions	Installation	Shipping Weight
EZO-25E	Elec-Hydraulic	115V, 1PH	2500	1.75	30.00	44 x 48	1	Not Anchored	1350
EZO-25E-3S	Elec-Hydraulic	115V, 1PH	2500	1.75	30.00	44 x 48	3	Anchor To Floor	1350

* Floor anchors are optional for EZO-25E and are required for EZO-25E-3S.

Model EZO-25E

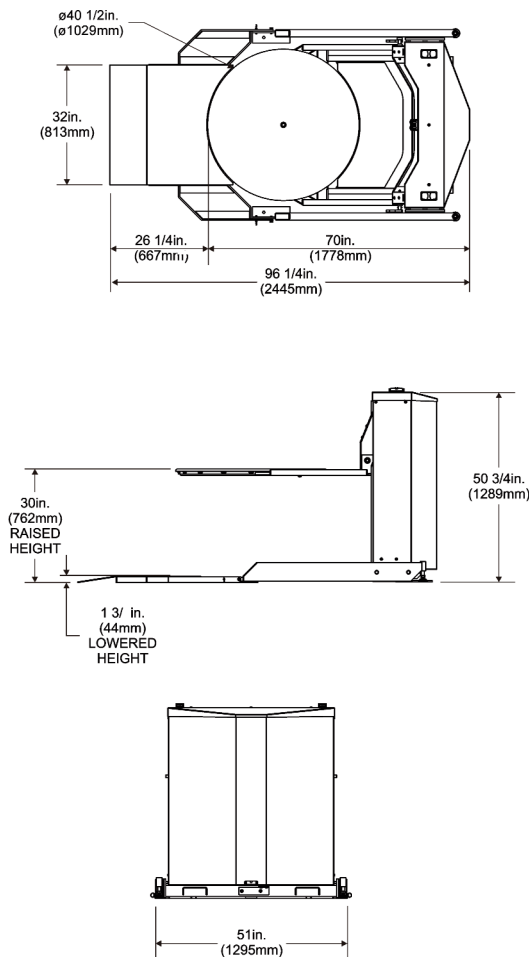

Model EZO-35E-3S

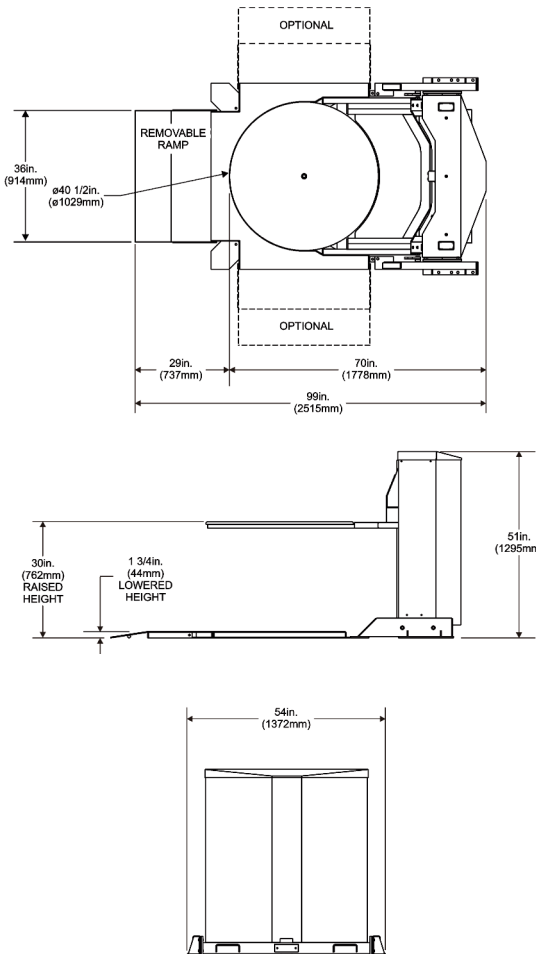

Standard Features

- Unique feet-clear safety circuit automatically stops the platform descent 9 in. above the floor surface preventing unintentional foot entrapment under the platform or pallet
- Safety warning lights and alarm alert the operator before the platform lowers from the intermediate safety stop
- Platform safety covers and chain cover guard against pinch points around mast, chain and rollers
- Chain cover guards pinch points around the upper chain wheel
- Unitized power unit / reservoir
- 1/2 HP, 115V electric motor
- 40.5 in. diameter rotating disk supported by 32 precision ball bearings
- Automatic platform lock prevents platform rotation in the lowered position
- Integrated approach ramp
- Lifting tabs and platform catches for transporting with a fork truck
- Rear leveling feet (EZO-25E)
- EZO-25E-3S offers three ramp position options & pallet stop
- Durable powder coated finish
- Protected by US Patent

Warranty :

Bishamon Industries Corporation warrants its products to be free from defects in material and workmanship for a period of one (1) year from the date of initial shipment. This warranty shall not apply to any misuse, mishandling, accident, shipping, alteration, or unauthorized repair of any Bishamon product or part. For complete details of warranty, please contact Bishamon at: 800-358-8833.

DISTRIBUTED BY:



Bishamon Industries Corporation

5651 East Francis Street
Ontario, California 91761-3601

Ph: 800-358-8833 US & Canada
909-390-0055 Outside US/CN

Fax: 800-700-0492

www.bishamon.com

BIC-EZO-2-18

Working Harder To Make Your Job Easier